

DOSING TECHNOLOGY

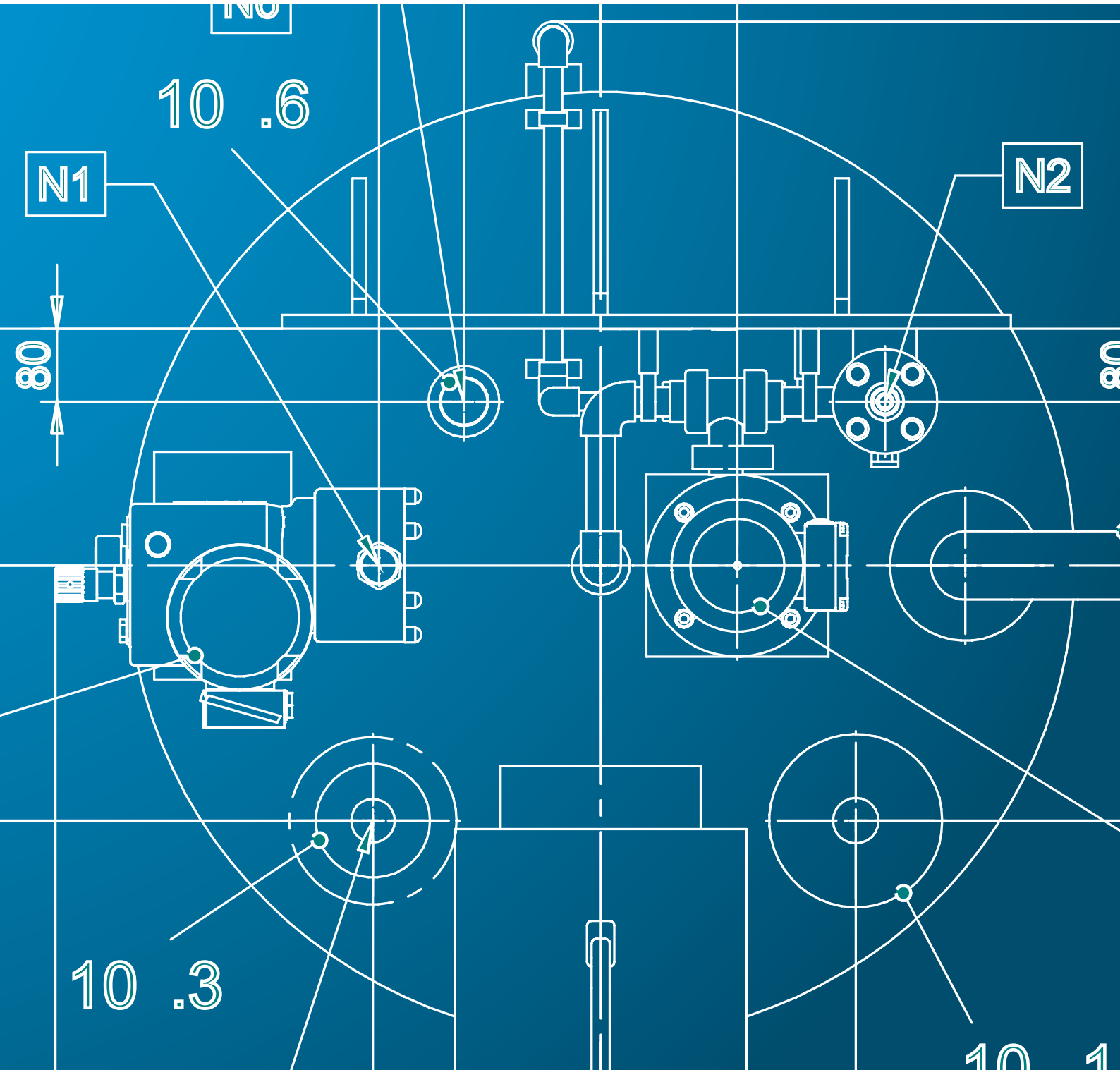

The image shows a modern building facade with a large glass window on the left and a white panel on the right. The 'sera' logo is mounted on the white panel, featuring a stylized 's' in a square followed by the word 'sera' in lowercase letters. The sun is shining brightly through the glass window, creating a lens flare effect. A blue semi-transparent box is overlaid on the right side of the image, containing the main text.

sera

An enterprise of the future

sera is one of the world's leading companies in the field of dosing and compressor technology, as the **sera** Group has been developing and producing application solutions which ensure precise dosing, conveying and compression of liquids and gases for over 70 years.

As an independent family business with its headquarters in Immenhausen, subsidiaries in the UK, South Africa and Spain and over 30 effective partners representing **sera** in more than 80 countries, we guarantee professional support, advice and services on the ground throughout the world.

EXCELLENCE IN FLUID TECHNOLOGY

We create added value for people and the environment.

Our customers and business partners, with their different needs and preferences, are always at the heart of our activities and actions. We inspire them with our products and services and impress them with our quality, expertise, speed and reliability.



Our foundation

With over 70 years of specialist knowledge and technological expertise behind us, we are system specialists in customized applications and we impress our customers with our integrated solutions and high-quality products.

Our aim

Customers are at the heart of everything we do. We therefore work with them to develop solutions that address their respective needs. Personal, professional support throughout the entire project process ensures that our customers get the best advice.

Our passion

sera stands for reliability, flexibility and innovation. We work professionally and passionately to inspire our customers with optimal solutions and durable, high quality products day in, day out.



DOSING TECHNOLOGY

We offer solutions - not just products

sera is your partner when it comes to developing and implementing customized solutions in the area of dosing technology.

By focusing specialist knowledge and technological expertise in our company, we are able to align ourselves effectively with the various industries and business areas of our customers.

sera ProDos has a wide range of products and develops solutions that are pioneering in terms of cost-efficiency, technology and ecology and are essential for

many areas of application such as water and wastewater treatment, disinfection and exact dosing and conveying of chemicals and liquids. They are used in many different sectors, including the food and beverage industry, breweries, the paper industry, the chemical and petrochemical sectors, power station technology and the textile and dye industries.

Products for system monitoring and planning and customized solutions round off our portfolio.

sera customers all over the world

also benefit from our extensive range of services.

From help with planning, via commissioning of systems, through to a fast and straightforward worldwide device replacement service, **sera** offers support in all project phases. We also train customers and potential customers in seminars relating to all aspects of dosing technology.



OGY

PUMP OVERVIEW

Solenoid diaphragm pumps

max. 35l/h, max. 10bar



SERIES:

204.1

FEATURES:

Easy operation,
Many features included in
standard,
Compact and economic,
High quality design

CONTROL:

Manual, Impulse,
Analogue

Diaphragm pumps

max. 1450l/h, max. 10bar



Multi-layer diaphragm pumps

max. 1200l/h, max. 20bar



Piston diaphragm pumps

max. 850l/h, max. 300bar



Piston pumps

max. 18l/h, max. 140bar



SERIES:

409.2

FEATURES:

Cost-effective high-pressure
pump,
Very high dosing accuracy,
Operational security thanks
to leakage nozzles

CONTROL:

Manual, Frequency conver
ter, Actuator, Control elect
ronics (Impulse, Analogue,
External), ProfiBus

Feed pumps

max. 3.100 l/h, max. 4 bar



Stepper motor pumps
max. 50l/h, max. 10bar



SERIES: iSTEP
FEATURES: Adjustment range 1:1000, Batch dispensing with recipe storage, Week-/Daytimer, Diaphragm monitoring, Service indicator, Intuitive and easy to use
CONTROL: Manual, Control electronics (Impulse, Analogue, External), ProfiBus



SERIES: 409.2 / 410.2
FEATURES: High operational security, Complete leakage-free, Safe to run dry and self-priming, Cost-effective, max. 5 heads up to 7.500 l/h, CIP design
CONTROL: Manual, Frequency converter, Actuator, Control electronics (Impulse, Analogue, External), ProfiBus



SERIES: 409.2 / 410.2
FEATURES: Very high operational security, Diaphragm service life up to 10.000 h,* Diaphragm monitoring, max. 5 heads up to 6.000 l/h, up to 100°C (fluid temp.)
CONTROL: Manual, Frequency converter, Actuator, Control electronics (Impulse, Analogue, External), ProfiBus



SERIES: 409.2 / 410.2 / 509.1
FEATURES: Very high operational security, Diaphragm service life up to 10.000 h,* Diaphragm monitoring, max. 5 heads up to 4.000 l/h
CONTROL: Manual, Frequency converter, Actuator, Control electronics (Impulse, Analogue, External), ProfiBus

SERIES: 411.3
DISPLACER: Single-diaphragm
FEATURES: low-maintenance transfer pump, up to 8m WC, Easy handling, Leakage-free, Unlimited safe to run dry and selfpriming
CONTROL: Manual, Frequency converter

Air driven diaphragm pumps
max. 50m³/h, max. 7bar



SERIES: APB / APE
FEATURES: Low-maintenance, Safe to run dry, Overrange protected
CONTROL: By compressed air

* Depends on operating conditions

MODULAR SYSTEM

SOLENOID PUMPS



204.1

STEPPER MOTOR PUMPS



iSTEP



409.2

	STROKE ADJUSTMENTS
Manually with simple scale	
	
Manually with position indicator	
	
Electrically with actuator	

CONTROL UNITS

optional with ProfiBus



C



Pro+

HOUSING TYPES

optional with stroke frequency initiator



409.2



410.2

MOTOR PUMPS



410.2



411.3



509.1

AIR DRIVEN PUMPS



APB/APE

DRIVES



DSM / WSM



DSM (FU)

DISPLACER



Single-diaphragm



Multilayer-diaphragm



Piston-diaphragm

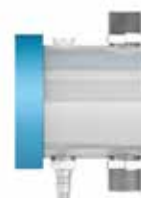

Piston



Plunger

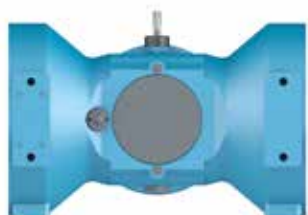

411.3



509.1

Not all available versions and options are shown here. This is a simplified scheme. Visit our website for more information or call: +49 5673/999.02.

SOLENOID DIAPHRAGM PUMPS - FOR SIMPLE DOSING TASKS

Operating range up to max. 10 bar / 35 l/h

Solenoid diaphragm pumps of the 204.1 series are electronically controlled, versatile dosing pumps for maximum operational reliability in a robust industrial design. The pump is easy to operate and has an output range of 0.4 l/h to 35 l/h at pressures up to 10 bar.

SAMPLE APPLICATIONS

For exact, process-dependent dosing of slightly outgassing media in all areas of industry.

OPTIONAL DESIGNS

- PROFIBUS DP - interface - optional

ADVANTAGES AT A GLANCE

- Directly controllable
- PROFIBUS DP - interface - optional
- High dosing accuracy
- Long diaphragm service life
- High-grade materials
- Linear control characteristics
- Low-maintenance
- Low operating costs
- Leakage-free
- Can be run dry indefinitely
- Easy to use
- Low weight



DESIGNS

MATERIALS

The high quality of the materials guarantees long-term, operationally reliable use. The right material is available to meet every need.

PUMP BODIES AND VALVES

PVC, PP, PVDF, 1.4571,
PP-GFK, PVDF-GFK

VALVE BALLS

PTFE, 1.4401, Al₂O₃

VALVE SEALS

EPDM, FPM, FEP-coated, FFKM

WORKING DIAPHRAGM

PTFE-faced

MANUAL VENT VALVE

PP-FRP, PVDF-FRP

DRIVE

The drive unit of the **sera** solenoid diaphragm pumps consists of a powerful lifting magnet in a strong plastic housing. The non-turning lifting magnet is equipped with a thermal overload protection device.

ACCESSORIES

- Flow controller
- Flow meter
- PROFIBUS components

We supply all accessories required for the optimal installation of dosing pumps, including relief valves, loading valves, pulsation dampers, dosing valves, dosing tanks, flow monitors etc.



- | | |
|---|----------------|
| 1 | Drive solenoid |
| 2 | Pressure valve |
| 3 | Vent valve |
| 4 | Pump body |
| 5 | Diaphragm |
| 6 | Suction valve |

MULTIPHASE MOTOR PUMPS - FOR CHALLENGING DOSING TASKS

Operating range up to max. 10 bar / 50 l/h

The **sera** iSTEP multiphase motor dosing pump combines an intelligent drive concept with the accuracy of a diaphragm dosing pump and sets new standards in terms of reproducibility and reliability. Thanks to the variable frequency control and an output range of 20 ml/h...50 l/h at 10...3 bar, the possible applications are almost unlimited. It is intuitive to use, durable and particularly suited for demanding dosing tasks.

SAMPLE APPLICATIONS

- Chlorine dosing for treatment of drinking water
- Flocculating agent dosing in sewage treatment
- Dosing of flocculant aids
- CIP applications

INPUTS & OUTPUTS

- 3 inputs programmable as
 - 3x digital inputs
 - 2x analogue inputs 0/4...20mA
- 2 digital outputs
- 1 analogue output for 0/4...20mA signal
- All inputs and outputs are freely configurable

ADVANTAGES AT A GLANCE

- Extremely large output range with just one pump
- Adjustment range 1:1000, can therefore be adjusted optimally
- Low-pulsation dosing
- Microprocessor-controlled drive
- Remote design
- Energy-efficient drive technology (low annual energy costs)
- Batch dosing and recipe storage
- Intuitive menu control including configuration
- Pulse scaling
- Day/timer function with 10 storage slots
- Low chemical consumption thanks to high dosing accuracy
- Slow mode for viscous substances



DESIGNS

MATERIALS

The high quality of the materials guarantees long-term, operationally reliable use. The right material is available to meet every need.

PUMP BODIES AND VALVES

PVC, PP-FRP, PVDF, 1.4571, 1.4435

VALVE BALLS

PTFE, 1.4401

VALVE SEALS

EPDM, FPM, FEP-coated

WORKING DIAPHRAGM

PTFE-faced

DRIVE

The drive unit of the iSTEP consists of a multiphase motor, coupled to a precise eccentric drive in a strong plastic housing. **sera** housings and base rings cope with any requirements and can, for example, withstand chemical attack because of the material they are made from.

CONTROL

The flow rate of the **sera** multiphase motor pumps can be controlled continuously by hand or by means of signals. An adjustment range of 1:1000 can be covered in this way. The stroke speed is used as the control mechanism.

SPECIAL DESIGNS

We offer individual solutions for special dosing tasks, including spring-loaded valves, tri-clamp connection and integration into a PROFIBUS/PROFINET network with the INTERFACE MODULE.

ACCESSORIES

We supply all accessories required for the optimal installation of dosing pumps, including relief valves, loading valves, pulsation dampers, dosing valves, dosing tanks, flow monitors etc.

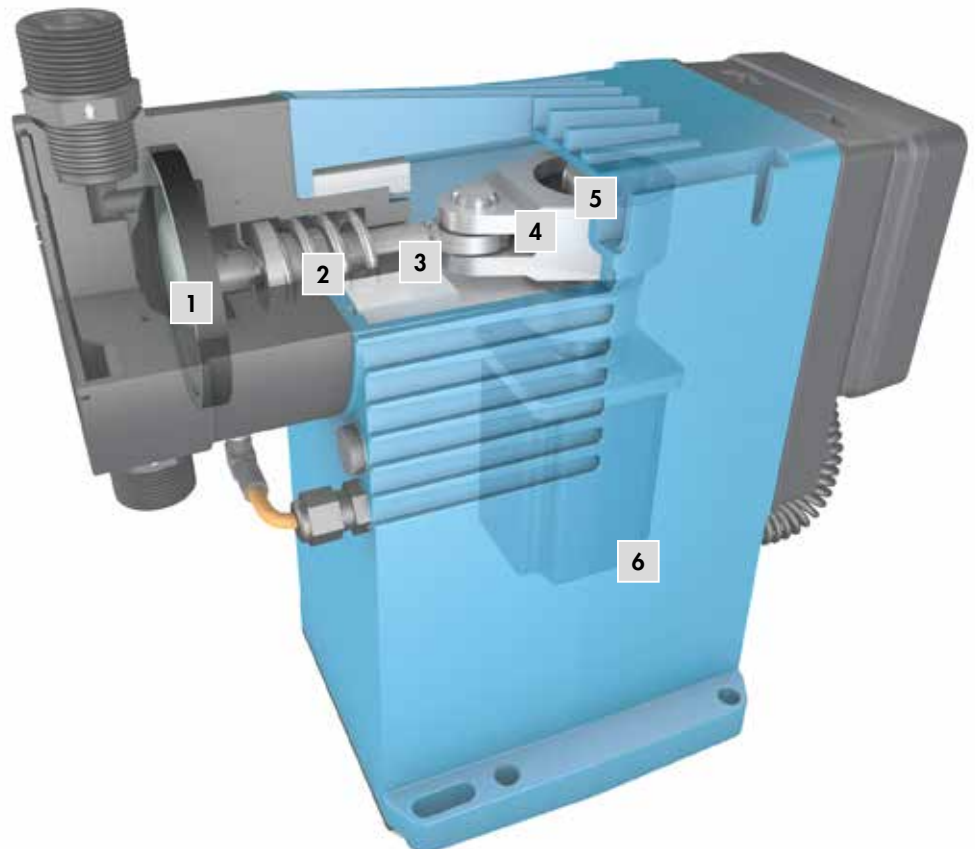

1	Diaphragm
2	Pressure spring
3	Connection rod
4	Driving rod
5	Eccentric shaft
6	Multiphase motor

DIAPHRAGM PUMPS - THE ALLROUNDERS

Operating range up to max. 10 bar / 1450 l/h

sera diaphragm pumps are oscillating positive displacement pumps for dosing liquids. The medium to be conveyed is separated from the drive by a diaphragm. It is therefore protected from the damaging effects of the medium. They are used wherever leak-free and precise dosing is important, as with corrosive, malodorous, abrasive, flammable, viscous or toxic media. The flow rate is adjusted by stroke frequency adjustment by means of an externally fitted frequency converter or control electronics (C-variant) and manual stroke length adjustment for optimal adjustment to any requirements.

SAMPLE APPLICATIONS

- Beverage industry
- Food industry
- Dye and paint manufacturing
- Power station technology
- Water treatment
- Shipbuilding
- Electroplating
- Textile industry
- Wastewater treatment

AUTOMATIC FLOW RATE ADJUSTMENT

- Three-phase motors suitable for use with an external frequency converter to adjust the stroke frequency
- Actuators with positioning controllers for automatic stroke length adjustment
- C-design with control electronics
- Three-phase motors with fitted frequency converter

ADVANTAGES AT A GLANCE

- High dosing accuracy
- Long diaphragm service life
- Linear control characteristics
- Leakage-free
- Low-maintenance
- ATEX-compliant designs available (not in stock)
- Can be run dry indefinitely
- Usable for larger suction heights

OPTIONAL DESIGNS

- Diaphragm monitoring
- Controllable variants
- Stroke frequency sensor



DESIGNS

MATERIALS

The high quality of the materials guarantees long-term, operationally reliable use. The right material is available to meet every need.

PUMP BODIES AND VALVES

PP, PVC-U, PVDF, PP-FRP, PVDF-FRP, 1.4571

VALVE BALLS

PTFE, 1.4401

VALVE SEALS

FPM, EPDM, FEP-coated

WORKING DIAPHRAGM

PTFE-faced, EPDM, FPM

MANUAL VENT VALVE (2.4e)

PP-FRP, PVDF-FRP

DRIVE

Each drive unit consists of a proven motor model, coupled with a stroke mechanism in a robust motor housing.

sera housings can cope with even the harshest conditions. Their material thickness and surface treatment can even withstand chemical attacks.

The flow rate can be constant or controlled continuously. In the controllable design, this is achieved manually by adjustment of the stroke length. Automatic flow rate adjustment can be carried out by means of the following options:

- Three-phase motors suitable for use with an external frequency converter to adjust the stroke frequency
- Three-phase motors with integrated frequency converter
- Integrated control electronics
- Actuators with positioning controllers for automatic stroke length adjustment

SPECIAL DESIGNS

We offer individual solutions for special dosing tasks:

These include pump bodies with special nominal widths, double valve designs and with spring-loading, with elastic ball seats, flushing devices for interval or final flushing to prevent sediments in pump bodies, integration of stroke encoders, diaphragm rupture monitoring, special materials such as titanium or Hastelloy, CIP design.

ACCESSORIES

We supply all accessories required for the optimal installation of dosing pumps, including relief valves, loading valves, pulsation dampers, dosing valves, dosing tanks, flow monitors etc.

1	Return spring
2	Connection rod plate
3	Eccentric shaft
4	Adjusting spindle
5	Setting wheel

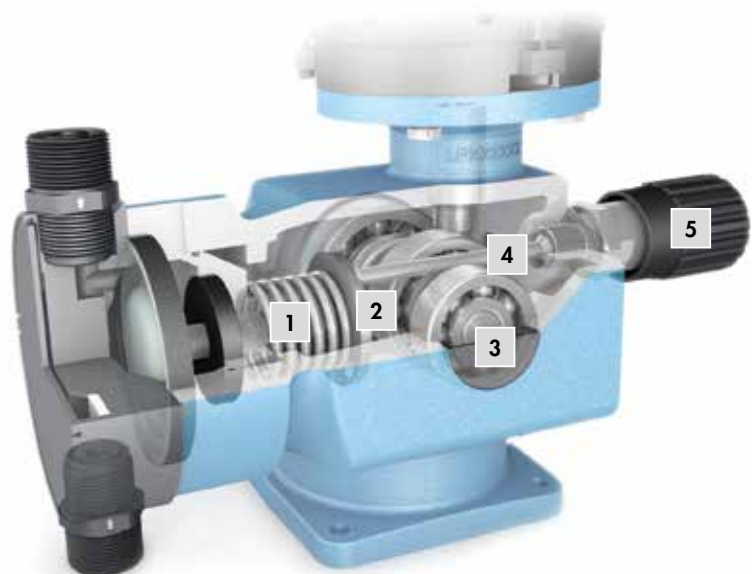

MULTI-LAYER DIAPHRAGM PUMPS MAXIMUM PROCESS RELIABILITY

Operating range up to max. 20 bar / 1440 l/h

sera multi-layer diaphragm pumps work according to the same functional principle as conventional diaphragm pumps, i.e. the diaphragm is oscillated mechanically by means of a connection rod and as a result, the dosing medium is moved.

SAMPLE APPLICATIONS

- Cleaning in place (CIP)
- Wastewater treatment
- Exhaust gas treatment
- Process industry
- Ex areas
- Chemical industry

MULTI-LAYER DIAPHRAGMS

Complex dosing tasks as far as technical safety is concerned can be completed by using multi-layer diaphragms. The greater safety requirements are taken into account by the significantly longer diaphragm service life compared to single-layer diaphragms and diaphragm monitoring (pressure switches, manometers, etc.).

MULTI-LAYER DIAPHRAGM PACKAGE

This consists of three PTFE diaphragms. This concept with diaphragm monitoring as standard ensures that there are absolutely no leaks if the working diaphragm is damaged. Damage to the working diaphragm does not result in direct dosing pump failure.

ADVANTAGES AT A GLANCE

- High operational reliability thanks to the multi-layer diaphragm technology
- Diaphragm status display via integrated diaphragm monitoring system (optical as standard/electrical available as an option)
- Outstanding suction properties with no additional components
- Can be used in areas with explosion protection with optional equipment variants
- Also suitable for higher medium temperatures and higher pressures

CONTROLLABLE VARIANTS

- Future-proof pump concept with integrated, multi-functional control electronics
- Easy commissioning with "Plug&Dose"
- High reliability with viscous media thanks to slow mode technology



DESIGNS

MATERIALS

The high quality of the materials guarantees long-term, operationally reliable use. The right material is available to meet every need.

PUMP BODIES AND VALVES

PVC, PP, PVDF, 1.4571, PP-FRP, PVDF-FRP,

VALVE BALLS

PTFE, 1.4401, Hastelloy

VALVE SEALS

EPDM, FPM, FEP-coated

WORKING DIAPHRAGM

PTFE (3-ply)

DRIVE

Each drive unit consists of a proven motor model, coupled with a stroke mechanism in a robust housing.

sera housings can cope with even the harshest conditions. Their material thickness and surface treatment can even withstand chemical attacks.

CONTROL

The flow rate of the **sera** multi-layer diaphragm pump can be controlled constantly or continuously.

- Three-phase motors suitable for use with an external frequency converter to adjust the stroke frequency
- Three-phase motors with integrated frequency converter
- Integrated control electronics
- Actuators with positioning controllers for automatic stroke length adjustment

SPECIAL DESIGNS

We offer individual solutions for special dosing tasks:

These include double valves, valves with spring loading, integrated stroke encoders, electric actuators.

We also offer special materials such as titanium or Hastelloy.

ACCESSORIES

We supply all accessories required for optimal installation of dosing pumps, including relief valves, loading valves, pulsation dampers, dosing valves, dosing tanks, flow monitors etc.

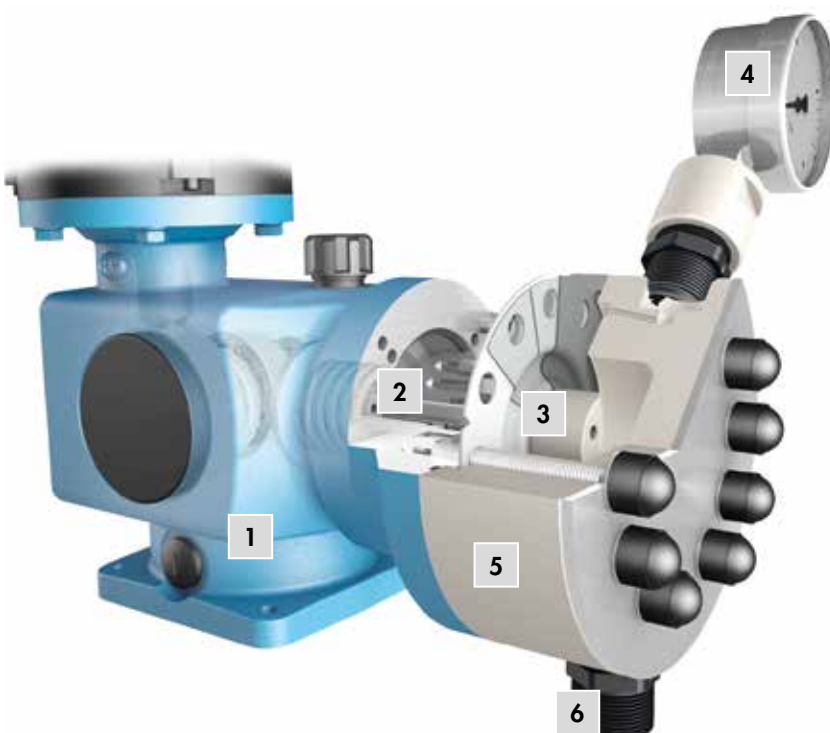

1	Stroke mechanism
2	Connection rod
3	Multi-layer diaphragm package: <ul style="list-style-type: none">• Working diaphragm• Signal diaphragm• Protective diaphragm
4	Diaphragm monitoring by <ul style="list-style-type: none">• manometer• pressure switch
5	Pump body
6	Suction valve

PISTON DIAPHRAGM PUMPS

VERSATILE APPLICATION

Operating range up to max. 80 bar / 1020 l/h

The stroke movement of the mechanically controlled piston is transmitted to the multi-layer diaphragms hydraulically. An integrated compensating valve guarantees exceptional dosing accuracy and offers optimal overload protection: If the counterpressure is excessive, the hydraulic fluid can escape into the compensating valve.

SAMPLE APPLICATIONS

- Power station technology
- Drinking water treatment
- Wastewater treatment
- Brewery technology

MULTI-LAYER DIAPHRAGMS

Complex dosing tasks as far as technical safety is concerned can be completed by using multi-layer diaphragms, as the diaphragm rupture monitoring system (pressure switch, manometer, etc.) takes account of the greater safety requirements. The diaphragm service life is also significantly longer than single-layer diaphragms. A rupture in the diaphragm does not lead directly to failure of the dosing pump.

ADVANTAGES AT A GLANCE

- High operational reliability thanks to the multi-layer diaphragm technology
- Diaphragm status display via integrated diaphragm monitoring system (optical as standard/electrical available as an option)
- Outstanding suction properties with no additional components
- Can be used in areas with explosion protection with optional equipment variants
- High pressures with piston diaphragm technology
- Integrated overpressure protection with relief valve in the hydraulic space

ADVANTAGES OF CONTROLLABLE VARIANTS

- Future-proof pump concept with integrated, multi-functional control electronics
- Easy commissioning with "Plug&Dose"
- High reliability with viscous media thanks to slow mode technology



DESIGNS

MATERIALS

The high quality of the materials guarantees long-term, operationally reliable use. The right material is available to meet every need.

PUMP BODIES AND VALVES

PVC, PP, PVDF, 1.4571, PP-FRP, PVDF-FRP,

VALVE BALLS

PTFE, 1.4401

VALVE SEALS

EPDM, FPM, FEP-coated

WORKING DIAPHRAGM

PTFE (3-ply)

DRIVE

Each drive unit consists of a proven motor model, coupled with a stroke mechanism in a robust motor housing.

sera housings can cope with even the harshest conditions. Their material thickness and surface treatment can even withstand chemical attack.

CONTROL

The flow rate of the **sera** piston diaphragm pump can be constant or continuously controlled.

Manual flow rate adjustment by:

- Stroke length adjustment

Automatic flow rate adjustment, depending on analogue or digital input signals, with:

- Three-phase motors with frequency converter for stroke frequency adjustment
- Actuators with positioning controllers for stroke length adjustment
- C-variant

SPECIAL DESIGNS

We offer individual solutions for special dosing tasks:

These include double valves, valves with spring loading, integrated stroke encoders, electric actuators. We also offer a model for explosive areas and special materials such as titanium or Hastelloy.

ACCESSORIES

We supply all accessories required for optimal installation of dosing pumps, including relief valves, loading valves, pulsation dampers, dosing valves, dosing tanks, flow monitors etc.

1	Pump body
2	Diaphragm monitoring by <ul style="list-style-type: none">• manometer• pressure switch
3	Multi-layer diaphragm package: <ul style="list-style-type: none">• Working diaphragm• Signal diaphragm• Protective diaphragm
4	Hydraulic compensating valve
5	Piston
6	Stroke mechanism
7	Suction valve
8	Pressure valve

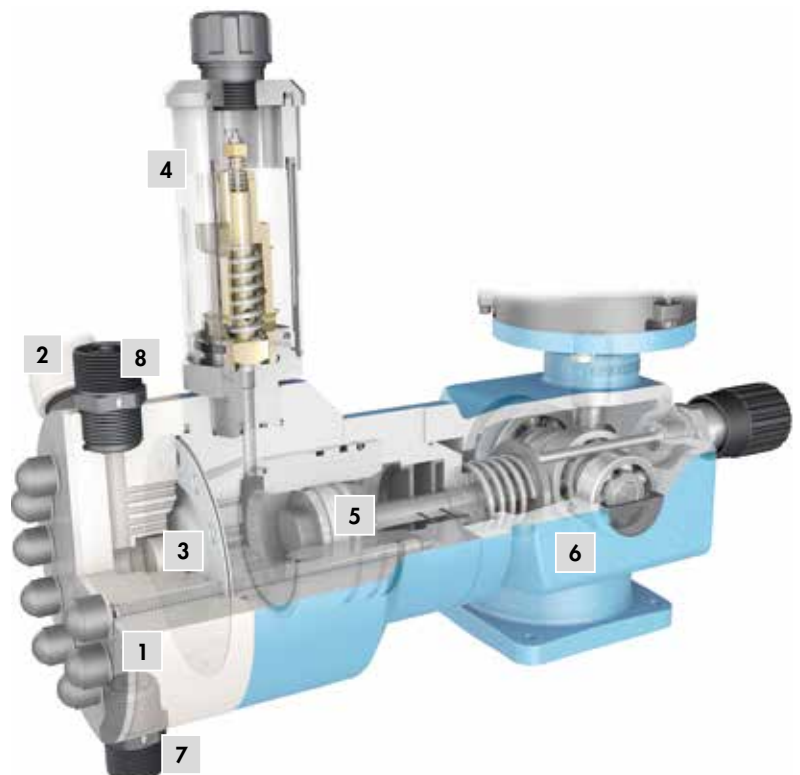

PROCESS PUMPS - LARGE OUTPUT RANGES

Operating range up to max. 300 bar / 89 l/h

sera 509.1 KM piston diaphragm pumps transmit the stroke movement of the mechanically controlled piston to the multi-layer diaphragms hydraulically. An integrated compensating valve guarantees outstanding dosing accuracy and optimal overload protection. The capacity can be adjusted via the stroke length using an eccentric adjuster. The capacity can also be adjusted via a speed control system with an external frequency converter.

SAMPLE APPLICATIONS

- Oil & gas industry
- Refineries
- Petrochemicals
- Chemicals
- Power station technology
- Energy
- Pharmaceuticals & cosmetics

AUTOMATIC FLOW RATE ADJUSTMENT

- Three-phase motors suitable for use with an external frequency converter to adjust the stroke frequency
- Actuators with positioning controllers for automatic stroke length adjustment
- Three-phase motors with integrated frequency converter

ADVANTAGES AT A GLANCE

- High dosing accuracy
- Counter pressure up to 300 bar
- Overload protection with integrated hydraulic valve
- High process reliability thanks to multi-layer diaphragms
- Diaphragm status display via integrated diaphragm monitoring system
- CE and EAC conformity certificates

OPTIONAL DESIGNS

- ATEX-compliant design
- API 675 standard

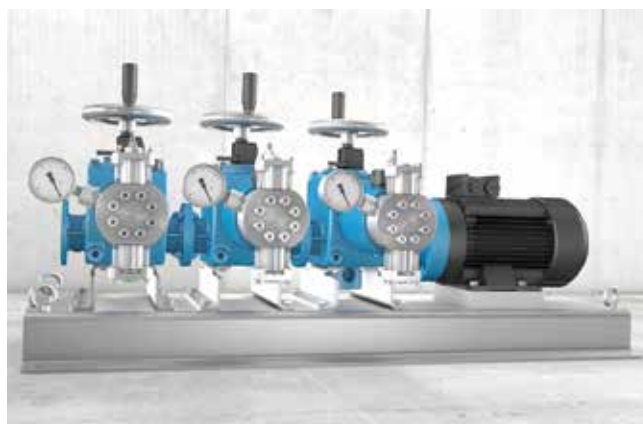

DESIGNS

MATERIALS

The materials used are suitable for almost any requirements and guarantee reliable continuous operation.

PUMP BODIES AND VALVES

1.4571

VALVE BALLS

1.4401

VALVE SEALS

FPM, FFKM

WORKING DIAPHRAGM

PTFE (3-ply)

DRIVE

Each drive unit consists of a proven motor model, coupled with a stroke mechanism in a robust housing.

sera housings can cope with even the harshest conditions. Their material thickness and surface treatment can even withstand chemical attack.

CONTROLS

The flow rate can be constant or controlled continuously.

Manual flow rate adjustment by:

- Stroke length adjustment by means of a variable eccentric
- Reproducibility +/- 1% at 10 - 100% stroke length

Automatic flow rate adjustment, depending on analogue input signals, with:

- Three-phase motors suitable for use with an external frequency converter to adjust the stroke frequency
- Actuators with positioning controllers for automatic stroke length adjustment
- Three-phase motors with integrated frequency converter

SPECIAL DESIGNS

We offer individual solutions for special dosing tasks:

duplex or triplex designs

ACCESSORIES

We supply all accessories required for optimal installation of dosing pumps, including relief valves, loading valves, pulsation dampers, dosing valves, dosing tanks, flow monitors etc.

509.1 KM
Stroke length adjustment using
manual setting wheel

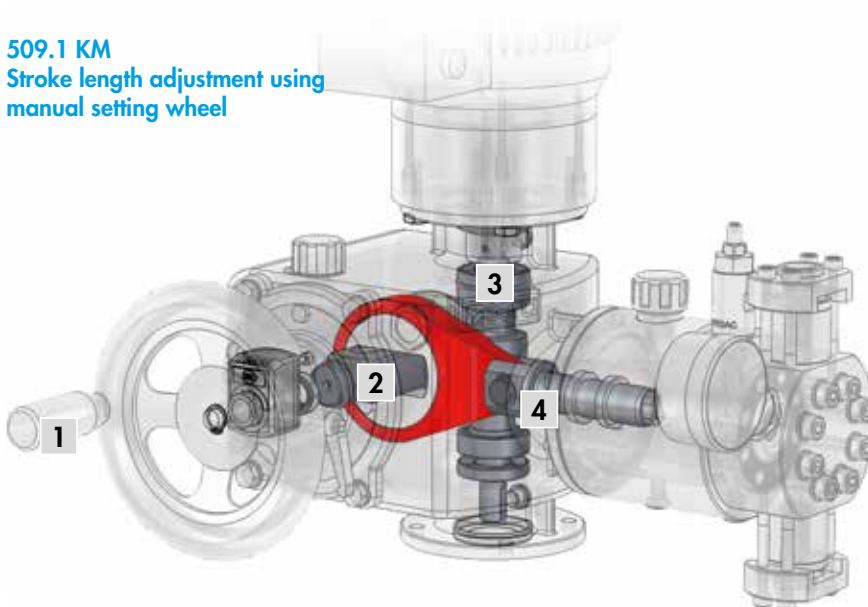

1 Setting wheel

2 Eccentric shaft

3 Drive shaft

4 Piston

PISTON PUMP - FOR HIGH PRESSURE

Operating range up to max. 140 bar / 22 l/h

The 409.2 - K is versatile in its application and extremely reliable despite its high pressure range. With low-wear components, hardly any maintenance work is required and the familiar quality and reliability is impressive.

SAMPLE APPLICATIONS

- Water treatment
- Food/drinks industry
- Chemical industry, petrochemicals, gas, refineries
- Power station technology
- Pharmaceuticals

ADVANTAGES AT A GLANCE

- Large pressure range
- High operational reliability
- Easy commissioning
- Extended operating range
- Robust design

PERFORMANCE FEATURES

- High pressure range with counter pressure up to 140 bar
- High operational reliability thanks to leakage nozzles and optional flushing nozzles
- Little maintenance work thanks to low-wear components
- Stroke mechanism in spring-cam drive design
- Linear/continuous adjustment of the stroke length from 0...100%, display of stroke length adjustment in standard design, manual stroke length adjustment
- Can be operated with frequency converter (RF design)



DESIGNS

MATERIALS

The high quality of the materials guarantees long-term, operationally reliable use. The high-quality stainless steel pump body withstands almost any pressure.

PUMP BODIES AND VALVES

1.4122V and 1.4571

VALVE BALLS

1.4401

VALVE SEALS

EPDM, FPM, FEP-coated

PISTON

1.4571

PISTON SEAL

PE

DRIVE

Each drive unit consists of a proven motor model, coupled with a stroke mechanism in a robust motor housing.

sera housings can cope with even the harshest conditions. Their material thickness and surface treatment can even withstand chemical attacks.

CONTROL

The flow rate of the **sera** piston pumps can be controlled constantly or continuously.

Manual flow rate adjustment by:

- Stroke length adjustment

Automatic flow rate adjustment, depending on analogue or digital input signals, with:

- Three-phase motors with frequency converter for stroke frequency adjustment
- Actuators with positioning controllers for stroke length adjustment

SPECIAL DESIGNS

We offer individual solutions for special dosing tasks:

These include flushing nozzles for flushing the leakage area, integrated stroke encoders, electric actuators.

ACCESSORIES

We supply all accessories required for optimal installation of dosing pumps, including relief valves, loading valves, pulsation dampers, dosing valves, dosing tanks, flow monitors etc.

AIR OPERATED AIR DIAPHRAGM PUMPS

Operating range up to max. 7 bar / 850 l/min

sera air operated diaphragm pumps are cost-effective, leakage-free positive displacement pumps. They have two diaphragms linked by a connecting rod. Compressed air is supplied alternately to the air chambers behind the diaphragms through an air control valve, so that one diaphragm is pushed forward while the other is pulled back (pressure/suction stroke). The special design of the air control valve ensures that the pumps can always be started up safely and there are no inconvenient downtimes. The valve balls open and close with the stroke rhythm of the diaphragms.

SAMPLE APPLICATIONS

- Food and Beverage industry
- Shipbuilding
- Electroplating
- Dye and paint manufacturing
- Textile industry
- Power stations
- Chemical intake systems

ADVANTAGES AT A GLANCE

- Available from stock
- Long service life
- Inexpensive
- Leakage-free
- Overpressure protection
- ATEX-compliant designs available (not in stock)
- Can be run dry

DESIGNS

MATERIALS

The high quality of the materials guarantees long-term, operationally reliable use. The right material is available to meet every need.

PUMP BODIES AND VALVES

PP, PP-CFK, ECTFE, PVDF, AISI 316

VALVE BALLS

Glass, PTFE, AISI 316

VALVE SEALS

FPM, EPDM, PTFE

WORKING DIAPHRAGM

NBR/PTFE, Santo-PTFE

ACCESSORIES

- MPD series pulsation dampers
- Compressed air supply units



FEEDING PUMPS

Operating range up to max. 4 bar / 3100 l/min

sera feeding pumps in the ZXM 411.3 and ZXRI 411.3 ranges are oscillating positive displacement pumps for conveying and dosing liquids in all areas of industry.

SAMPLE APPLICATIONS

- Drinks industry
- Shipbuilding
- Food industry
- Electroplating
- Dye and paint manufacturing
- Textile industry
- Power stations
- Chemical intake systems

PERFORMANCE FEATURES

- High dosing accuracy
- High-grade materials
- Linear control characteristics (ZXRI models)
- Low-maintenance
- Low operating costs
- Leakage-free
- Can be run dry indefinitely
- Easy to use
- Design in accordance with ATEX



DESIGNS

MATERIALS

The high quality of the materials guarantees long-term, operationally reliable use. The right material is available to meet every need.

PUMP BODIES AND VALVES

PVC, PP, PVDF, 1.4571

VALVE BALLS

PTFE, 1.4401, Hastelloy

VALVE SEALS

EPDM, FPM, FEP-coated

WORKING DIAPHRAGM

PTFE-laminated

ACCESSORIES

We supply all accessories required for optimal installation of dosing pumps, including valves, pulsation dampers, dosing valves, dosing tanks, flow monitors etc.

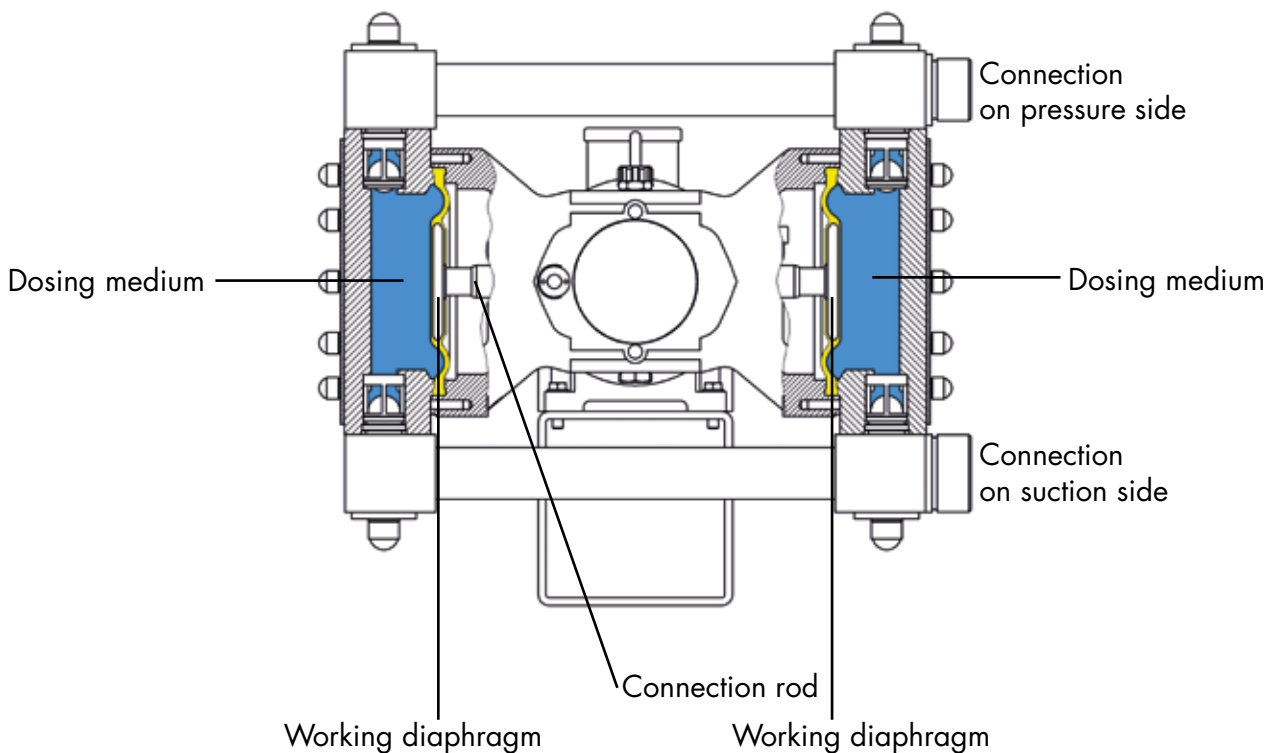

STANDARD DOSING SYSTEMS

Standard dosing systems are very versatile. They come into their own in particular when controlled, precise dosing of liquids is required in processes or in other media. The fully modular design allows users to customise their system with standard components according to their specific dosing requirements – much like a construction kit. A multitude of optional accessories also increases the range of applications and performance. These systems combine fast availability thanks to short delivery times, cost-effectiveness as a result of inexpensive modular system configuration and high-quality, technically perfect system solutions that are suitable for many customer applications.

SAMPLE APPLICATIONS

- Drinks industry
- Food industry
- Dye and paint manufacturing
- Power station technology
- Water treatment
- Shipbuilding
- Electroplating
- Textile industry
- Wastewater treatment

ADVANTAGES AT A GLANCE

- Maximum dosing accuracy and safety through the use of the latest dosing and pump technology
- High-quality materials that can be integrated and used flexibly and variably
- Minimal space required on site because of extremely compact design
- Small variety of parts because standard components are used
- Short delivery times and availability
- Minimal installation and commissioning work thanks to **sera** "Plug&Dose" standard configuration

DESIGNS



CVD1- COMPACT DOSING SYSTEM, VERTICAL

Flow rate: up to 1450 l/h
Pressure: up to 10 bar



CVD2 - COMPACT DOSING SYSTEM, VERTICAL

Flow rate: up to 2x 1450 l/h
Pressure: up to 10 bar



CTD - COMPACT DOSING STATION

Tank volume: 40-1000 litres

Flow rate: 0.4 - 570 l/h

Pressure: up to 10 bar



CHLORINE DIOXIDE SYSTEM

Output: up to 1000 g ClO₂/h



POLYLINE - PREPARATION AND DOSING UNITS

Polymer preparation volume: 500 - 8000 l/h



CAUSTIC SODA PREPARATION STATION

Caustic soda preparation volume: 1000 - 3000 l/h

PROCESS MEASURING AND CONTROL TECHNOLOGY

As a system provider, **sera** offers customised complete dosing systems (“turn key systems”) alongside its standard dosing systems and components, which are perfectly tailored to the specific customer requirements with extensive process measuring and control technology.

The **sera** service portfolio ranges from engineering, via programming, system assembly and inspection, to worldwide on-site installation and commissioning – all from a single source.

Thanks to the latest flow rate, fill level and measuring and control technology, all process parameters are monitored, evaluated and controlled directly in the dosing system or from a control centre, as required. Efficient use of chemicals is therefore guaranteed at all times (e.g. during mixing and preparation).

Communication between the controller and control system can take place by the conventional route, using analogue signals and floating contacts for example, or via on-site PLC and network connections for complex and sophisticated systems. All systems meet the latest VDI guidelines and European standards.

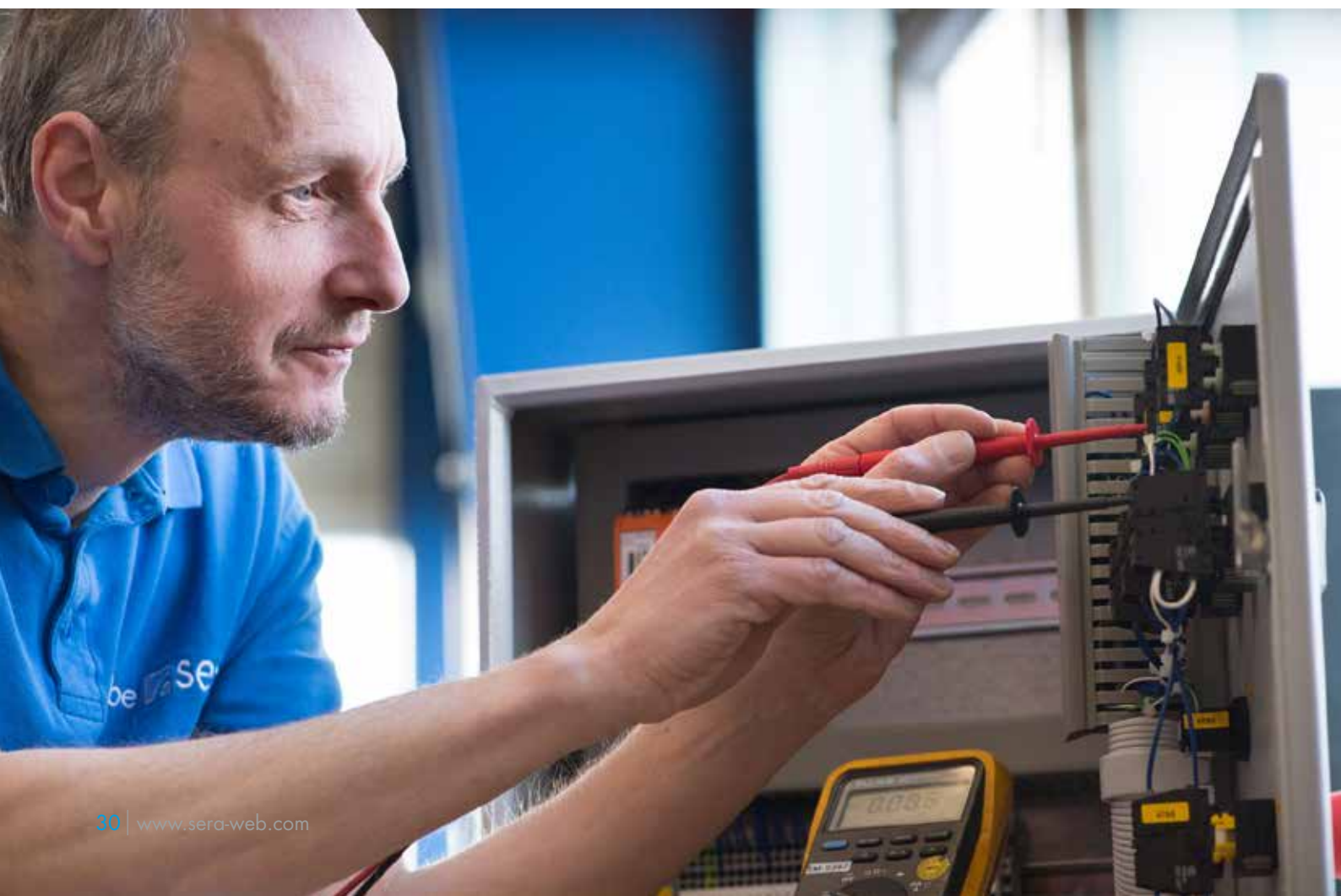



THE RIGHT ACCESSORIES FOR EVERY APPLICATION

sera offers an extensive range of dosing fittings and accessories for a wide variety of process tasks and system peripherals. Our range is available in a variety of materials and designs to maximise the operational reliability of the dosing units and systems for the application concerned.

sera pulsation dampers are approved and certified in accordance with the Pressure Equipment Directive (2014/68/EU).

The **sera** fittings and accessories range includes:

- Dosing, check and foot valves
- Pressure relief and loading valves
- Multifunctional valves
- Suction lances
- Pulsation dampers
- Ball cocks
- Priming aids/siphon vessels
- Calibration pots
- Injection fittings
- Line strainers
- Connectors
- Dosing hoses
- Dosing tanks
- Collecting basins
- Mixers and agitators
- Pressure gauges
- Dry material feeders
- Absorption vessels
- Measurement and control sensors

EFFICIENT SERVICES ANYWHERE IN THE WORLD

From planning, via commissioning of systems, through to a fast and straightforward worldwide device replacement service, **sera** offers support in all project phases. Our aim is to ensure that our customers continue to achieve the production results they are looking for with our systems, dosing units and pumps after commissioning is complete. High availability of the system with a minimum of system downtimes is essential to ensure this. To this end, **sera** offers a wide range of services, from technical support, via a spare parts service, to a repair service.

SERVICING & MAINTENANCE SERVICE

sera systems are serviced and maintained by experienced service technicians in order to avoid shutdowns. We offer an extensive range of service contracts, tailored to customer requirements. Early detection of possible causes of faults allows unexpected system shutdowns to be eliminated almost completely.

TECHNICAL SUPPORT

Whether it's for questions relating to **sera** products, help with system design or a solution for a specific requirement – our experienced, well-qualified **sera** service team will be happy to help.

CUSTOMER TRAINING COURSES

sera training courses are held at **sera's** headquarters in Immenhausen or, on request, on our customers' premises, and can be customer or application-based. You can find specific information about the current course dates in the Service section of our website.

ASSEMBLY & COMMISSIONING

Our trained **sera** service technicians are available for assembly and commissioning work. On request, assembly can also be carried out by the customer's technical personnel under the guidance of a **sera** service technician. In this way, the customer's technical staff become familiar with handling the new system in a very short time.

SPARE PARTS & REPAIR SERVICE

Quality, ease of servicing and durability can be taken for granted with our products. But if a spare or replacement part is needed, our spare parts service can deliver the part required quickly, as we have the majority of our spare parts in stock. If the entire pump is defective, it can either be sent for repair or a qualified **sera** service technician will come to you and repair it on site.

SERVICING OF NETZSCH PUMPS

We now also service eccentric worm pumps made by our partner Netzsch. Our experienced, well-qualified **sera** service team will be happy to help.





sera PLATO APP

Planning can be this easy

With the unique **sera** PLATO APP, which is available free of charge, **sera** offers all technical managers and planners of industrial and public effluent and sewage works an easy, cross-platform tool for configuration and technical specification of dosing systems for flocculating agents.

With just a few mouse clicks, the user can draw up perfect solutions for the process to be planned thanks to the intuitive user guidance and extensive help options. The tendering text can be saved in project folders or exported as a TXT, PDE, Word or GEAB file.

QR CODE

All information accessible immediately

The QR codes make service easier for the user. By scanning the code, which is unique to the service-number, with an appropriate QR code reader on a smart phone or tablet, the user is taken directly to the sera service portal, where the following information is available to download:

- Service contact
- Operating manual(s)
- Product information
- Article text
- Data sheets

WASTEWATER SOLUTIONS

We provide an extensive product range so that the best possible solutions for each step of the process are always available. Here are some examples of our product range for a typical wastewater treatment process:

- 1 **CONTAINER STATION**
Dosing of bivalent metal salts for the elimination of hydrogen sulphide (H_2S)
- 2 **DOSING STATION DAV4**
Dosing of carbon sources for denitrification, e.g. methanol, acetic acid, glycol
- 3 **MOBILE DOSING STATION**
Dosing of formic or acetic acid to descale ventilation systems
- 4 **DOSING STATION CVD2**
Dosing of flocculating agents such as $FeCl_3$, $Al_2(SO_4)_3$ for the elimination of phosphorus/phosphate precipitation
- 5 **POLYLINE**
Polymer preparation station for sludge conditioning for thickening/dewatering
- 6 **DOSING STATION CVD2**
Dosing of defoaming agents to reduce and prevent foam
- 7 **DOSING STATION CTD**
Dosing of e.g. sodium hypochlorite for downstream disinfection

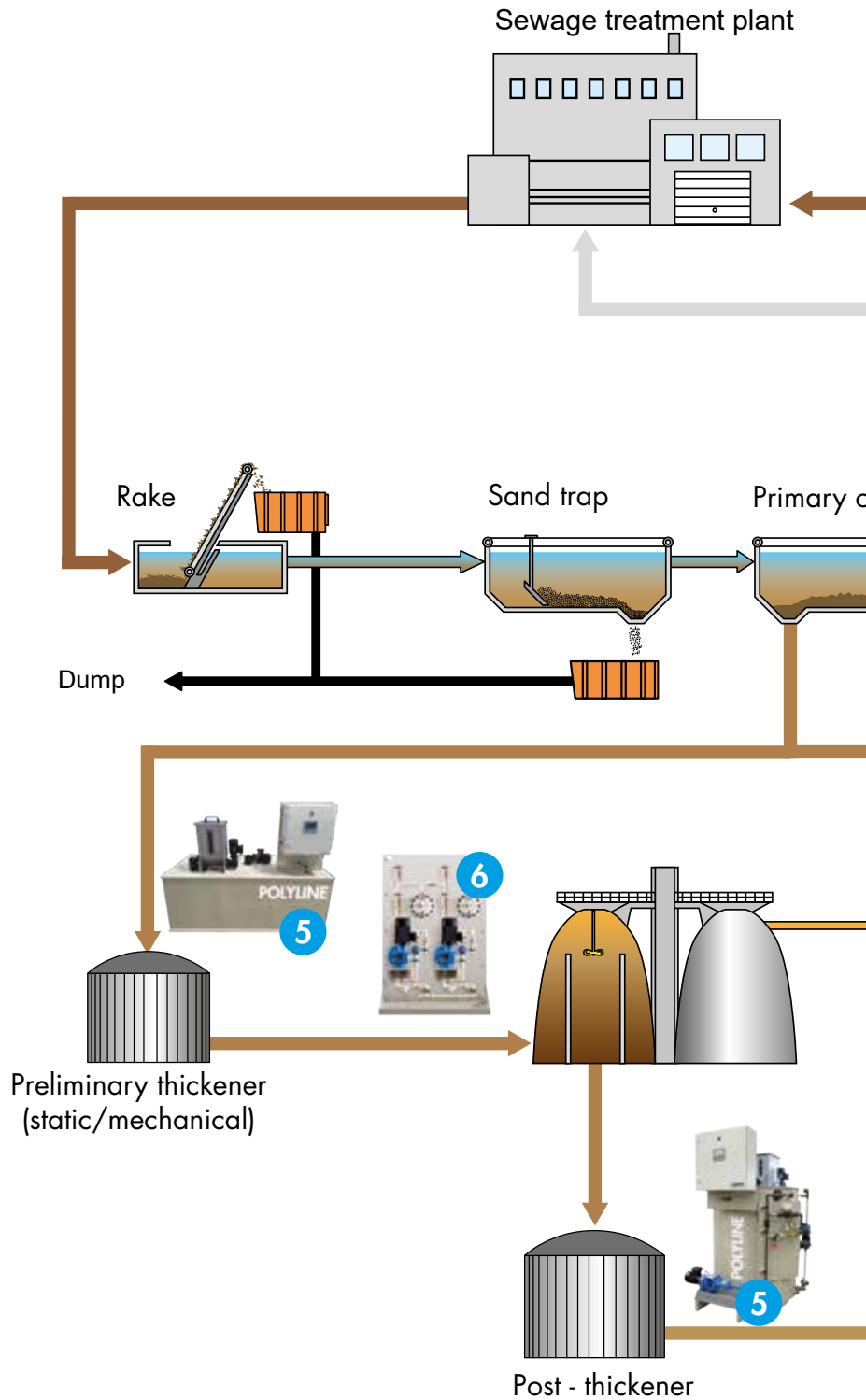

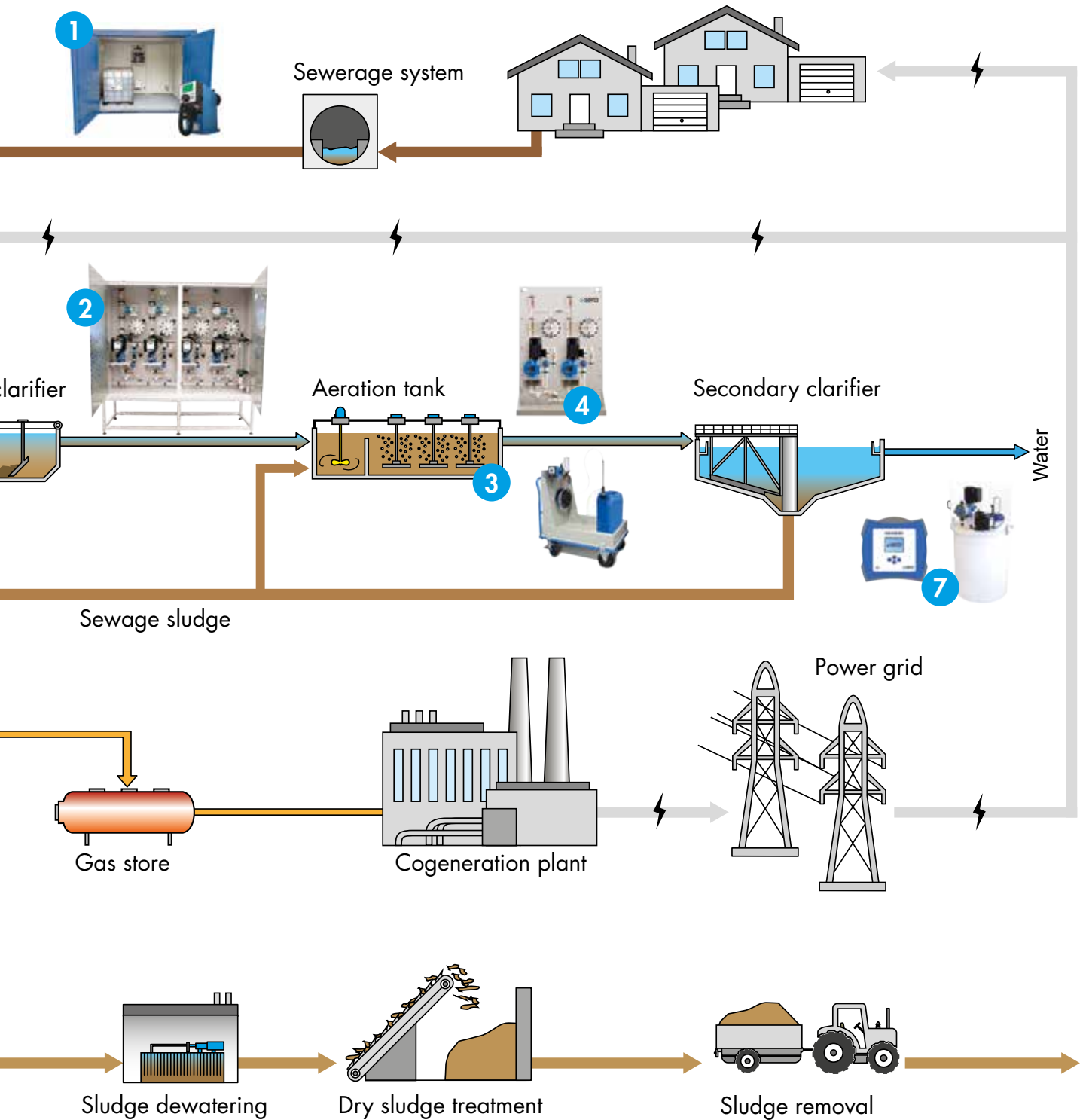

BREWERY SOLUTIONS

Wherever food is handled, the work area must be kept clean and tidy. This is especially true when it comes to brewing beer. Producing great tasting beer requires not only a sophisticated brewing process but also ways of cleaning and disinfecting industrial production systems and methods for treating all kinds of water needed for the brewing process.

We provide an extensive product range so that the best possible solutions for each step of the process are always available. Here are some examples of solutions from our comprehensive range, based on typical processes in brewery technology:

- 1 Addition of ClO_2 to disinfect drinking, process and cooling water
- 2 Caustic soda preparation
- 3 Enzyme dosing, disinfection, CIP
- 4 Enzyme dosing, disinfection, CIP
- 5 Dosing of calcium chloride (CaCl_2)
- 6 Dosing of calcium sulphate (CaSO_4)
- 7 Enzyme dosing, disinfection, CIP
- 8 Addition of Kieselguhr / beer filtration
- 9 Colouring agent dosing
- 10 Conveyor lubricant dosing
- 11 Dosing of chemicals
- 12 Addition of ClO_2 to disinfect drinking, process and cooling water

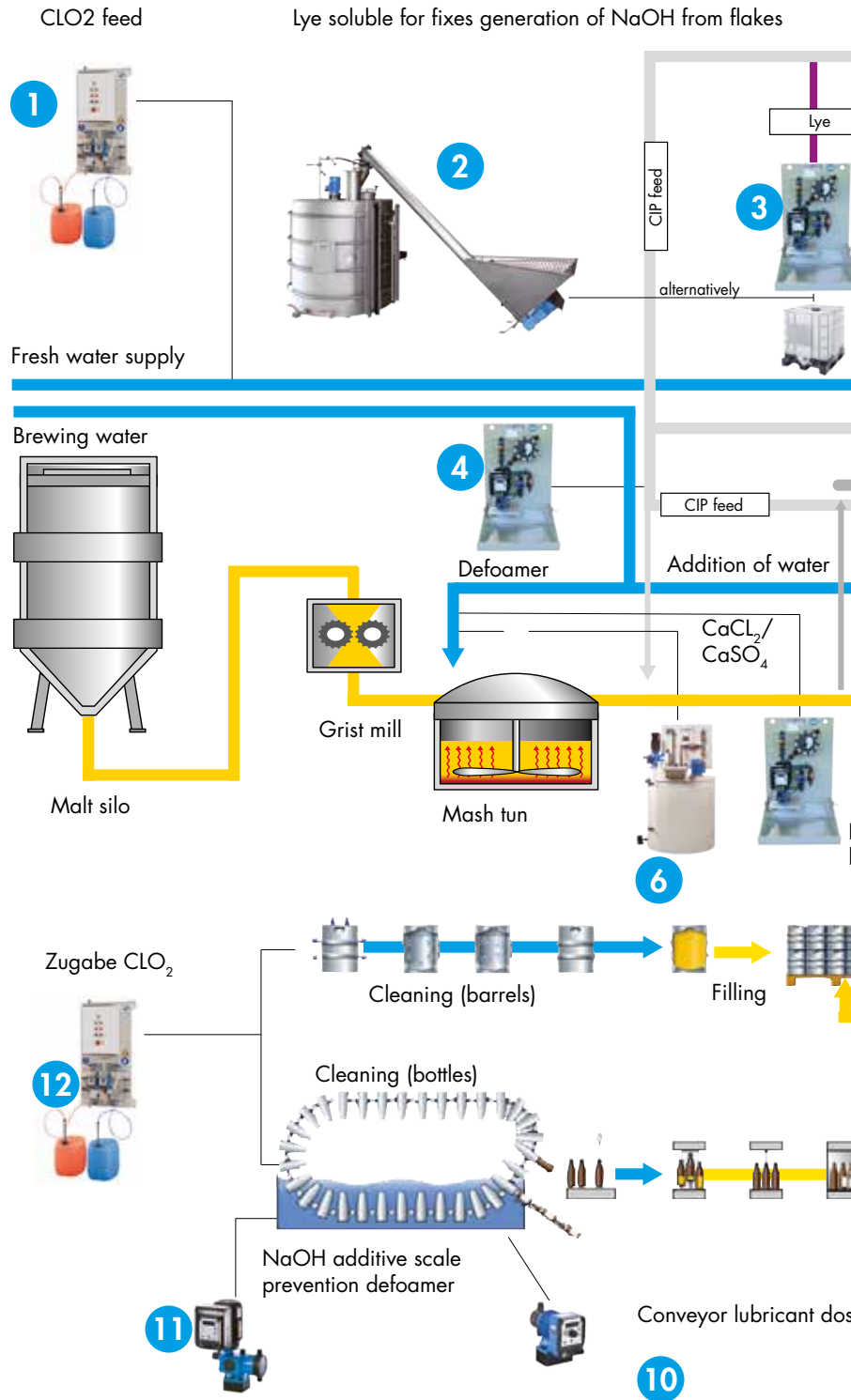

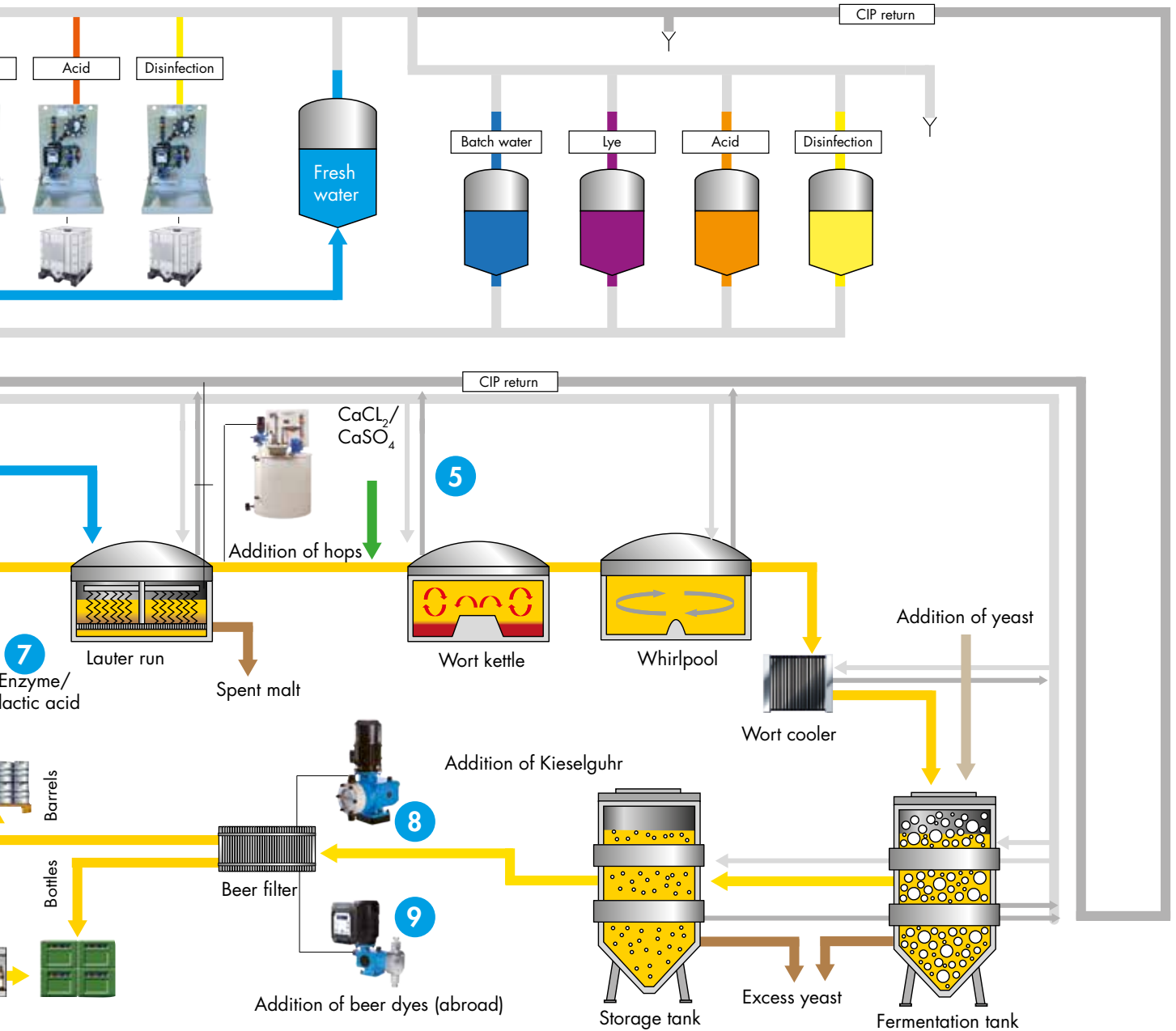

ing

INDUSTRIAL SOLUTIONS

The requirements and dosing processes of our customers are extremely varied in the area of industrial and process solutions. Individual challenges must be identified and resolved.

As a system provider of dosing technology, **sera** is able to understand these different processes and develop tailor-made solutions to meet any customer requirements.

Particular attention is devoted to considering the interfaces:
For which point in the customised process are our solutions intended and how can they be integrated smoothly?
Only when these essential questions have been answered can smooth project management be ensured for the customer.

sera is able to draw on a multitude of product solutions that it has developed itself to complete various dosing tasks, such as preparation and dosing stations with the associated dosing pumps and appropriate suction and pressure fittings.

A decision is made in each case about which components are actually required to complete the dosing task and which are not. As a result, the dosing systems are adapted to the needs of the specific application.

In terms of design, the individual parameters and customer requirements are implemented by the company's own engineering department, so that the customer has a customised solution for their dosing task – all from one source!

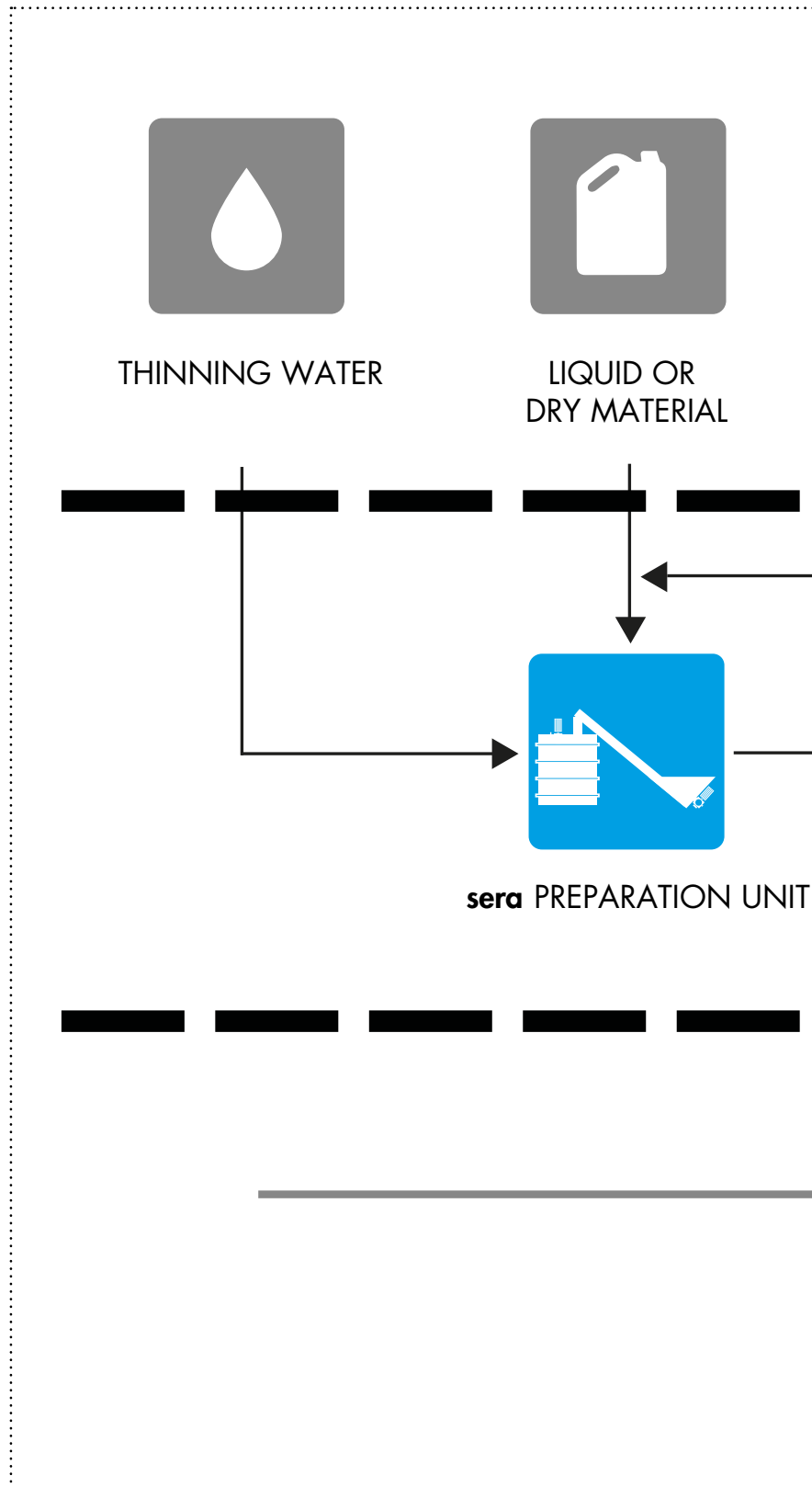

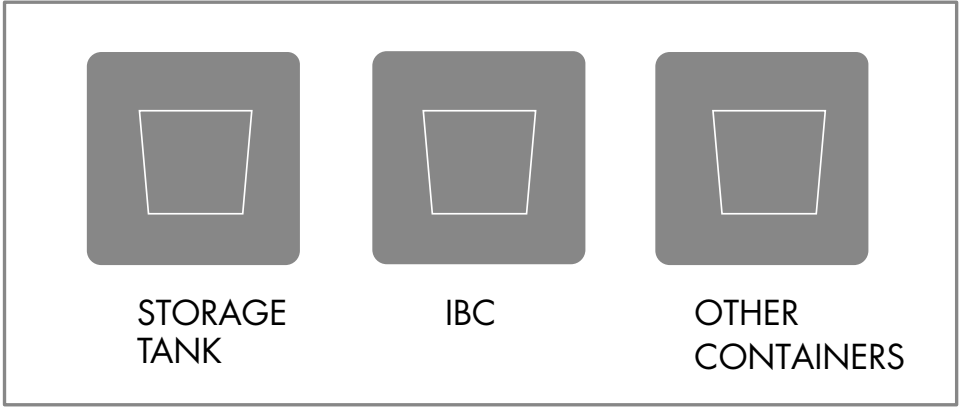

STARTING MATERIALS



sera
TRANSFER PUMP OR DRY
MATERIAL FEEDER



sera
SUCTION FITTINGS

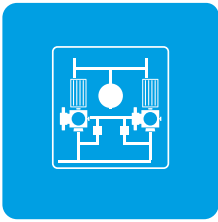

sera DOSING SYSTEM



sera
INJECTION FITTINGS

**sera
PRODUCT SOLUTIONS**



CUSTOMISED
PROCESS

CUSTOMER PROCESS

BONN - WASTE RECYCLING



Recycling of the waste from Bonn and the surrounding region is carried out by Müllverwertungsanlage Bonn GmbH (MVA), a subsidiary of Stadtwerke Bonn (Bonn Public Utilities). Over 1,000 tonnes of waste, which has to be disposed of in a safe and environmentally friendly way, is delivered to it every working day. In a complex thermal process, the waste is first incinerated and then processed. Flue gases are created when the refuse is burnt.

Their energy is recovered by means of a boiler or steam generator that is downstream from the incineration process. As the hot flue gases flow through the boiler, they are cooled down, while the boiler feed water heats up and evaporates. The steam created is then used to generate electricity and heat. In the downstream condenser, the steam is liquefied again and returned to the feed water.

The feed and boiler water must meet certain requirements to be able to operate a boiler safely and without causing damage.

sera designed and supplied a special dosing system

for the boiler plant at MVA Bonn. Two independent dosing systems for caustic soda and ammonia solution have been installed in this plant, which condition the boiler water in such a way that it corresponds to the specifications of the VGB guidelines for power station operation. Both systems have dosing pumps, fittings, 500 litre batching tanks, fill level sensors, collecting basins and space for delivery containers. As ammonia solution is a volatile chemical, this part of the system has a gas-tight design. A shared control cabinet monitors the two dosing systems and provides information to the control centre at MVA Bonn. Decentralised monitoring and control of the systems is therefore possible.

The application solutions are both made fully automatically and with level monitoring from a mixture of concentrate and water. Dosing of the prepared solutions is carried out with controllable **sera** diaphragm and/or piston pumps. The demand on and adjustment of the pumping capacities depend on the operation of the higher level system parts.

sera dosing pumps ensure that there is a consistent pH value in the boiler feed water by adding caustic soda and that the condensate has a pH value of approx. 9.5 to protect the feed water and condensate pipes.

In this way, the boiler and pipes in the thermal section of the MVA have the optimal permanent corrosion protection.



PHNOM PENH - HEINEKEN BREWERY



Approximately 50 million tons of caustic soda are produced annually and used in various ways in industry. **sera** has developed a cost-effective system solution specifically for use in the food industry, which has a variable but large demand for alkaline cleaning agents such as caustic soda. This enables safe and efficient preparation of caustic soda based on sodium hydroxide (NaOH) in solid form (pellets, flakes, pearls or powder) and water.

Breweries use caustic soda particularly because it is cost-effective: transport, delivery and storage of goods in sacks with undissolved solids is significantly less expensive than ready-made solutions. The extensive building work which is required to accommodate delivery of ready-made solutions in tankers containing hazardous substances is also unnecessary. Above all, however, the well-known suppliers in the drinks industry value the flexibility that they have with their own preparation unit: solutions are prepared as required and their concentration can be adjusted by increasing or lowering the amount of solid materials added.

These factors also played a part in the decision of Heineken, the operator of the Cambodia Brewery Ltd. in Phnom Penh, to go back to a caustic soda preparation unit in its renovation of the brewery in 2016.

The system supplied consists of a stainless steel batching tank, an agitator and a special conveyor that is separate from the batching tank. The conveyor consists of a feed hopper and a stainless steel screw-conveyor that carries the solid materials to the batch-

ing tank. With this design, the operating personnel are not in the immediate danger area of the batching tank in which the solid matter reacts exothermically with water.

The batching tank has a level indicator with a shut-off valve, a temperature display and a pipe safety cage to prevent accidental physical contact. The prepared solution is transferred into a larger storage tank either by a **sera** refilling system.

A **sera** CVD (Compact Vertical Dosing) system with a modular design is also provided to remove the solution from the storage tank and feed it precisely into the cleaning process.



STADTWERKE WINTERBERG

Winterberg, a centre of tourism in the Sauerland region with 13,000 inhabitants in 15 districts, has experienced a development boom in recent years and – from the point of view of tourism – has all the features of a typical destination in the central German uplands.

In order to give winter sports enthusiasts 80 days of guaranteed snow a year, a plan was drawn up in the 1990s to make snow. The scheme worked: in 2012, Winterberg recorded more than 1 million overnight stays for the first time – and that was in commercial hotels alone. Unrecorded stays with small and private accommodation providers and about 1.5 million day visitors a year should be added to this. Of course, this has consequences for the local sewage system. Stadtwerke Winterberg AöR (Winterberg Public Utilities) operates two sewage treatment plants which struggle especially in winter with sudden additional loads because of the increase in tourism. The operator built on our expertise to overcome two particular challenges in this connection:

the large number of day visitors has changed WC usage and the quantity of urea in the sewage has increased significantly. As a result, the amounts of carbon and nitrogen in the sewage are out of proportion. In normal public sewage, the ratio of carbon to nitrogen is 5:1, while in Winterberg it hovers around 2:1. This disproportionate ratio leads to a shortage of carbon in the denitrification period. Acetic acid is added to the sewage as a source of carbon to compensate for this. This supports the breakdown of nitrates into elemental nitrogen and the ratio of carbon to nitrogen is restored to the level required.

As a result of weeks of snow melting in Winterberg, the sewage also has very low temperatures, which

causes poor settling behaviour of the sewage sludge in the secondary clarification process. Addition of polymer flocculating agents improves the bonding and settling behaviour.

sera provided a solution for both challenges: the two sewage treatment plants were each supplied with a complete solution in an insulated hazardous material container with ventilation and heating. A DAV2 dosing system with spray protection doses the acetic acid from a 1,000 litre IBC into the denitrification system. Two iSTEP S50 multiphase motor pumps with a very large adjustment range of 50 ml/h to 50 l/h, supported by a controller, ensure that very large quantities of acetic acid can be added if necessary, but it is also possible to add small quantities of acetic acid continuously in the denitrification process.

Both turn-key containers also have a smart CTD small quantity dosing system to prepare and dose polymer flocculating agents. The polymer solution is prepared from a concentrate and water and is added to the feed to the secondary clarification system. The polymer is added automatically, depending on the turbidity in the secondary clarification system. Here, too, we used two iSTEP S50 pumps in order to offset fluctuations as effectively as possible. And this also facilitates easy maintenance and parts supply.

We are delighted that we were able to work with Stadtwerke Winterberg to develop and supply the right solution.



STADTWERKE FLENSBURG

We at **sera** are experts in the field of sewage sludge conditioning. We were therefore awarded the contract to build and supply a preparation unit for polymer flocculating agents as part of the reconstruction of the mechanical sludge thickening plant of Flensburg sewage works.

In the course of wastewater treatment, sewage sludge is created and its disposal and reuse is the responsibility of the plant operator. The aim here is to reduce the volume of sludge and increase the amount of dry material to simplify its reuse and minimise operating costs.

During mechanical sludge thickening in the belt thickener, the thin sludge is conditioned and filtered by adding polymer flocculating agents. Between the flocks, sludge water that has been released runs off through the filter material of the belt thickener as filtrate, while the flocculated solids are held back by it.

sera supplied a customised 2-chamber pendulum system for preparation and addition of the polymer flocculating agents. The system is made entirely of stainless steel and has two batching tanks with a usable volume of 2 m³ each. While water and polymer concentrate is prepared in one chamber in the predefined concentration and then mature, the other chamber is ready for removal. Our system ensures that the polymer flocculating agent is always prepared in the right proportions and with consistent quality, and is released as a stable solution.

Two eccentric worm pumps with dry running protection devices and overpressure protection convey the optimally prepared polymer solution into the belt

thickener and the process for mechanical sludge thickening.

Simple operation, maintenance and servicing were very important to the customer. The tanks were therefore supplied with covers of a special size to ensure easy access. The preparation system was also equipped with a customised controller with large 9" colour panel and integrated into the automation and control equipment of the mechanical sludge thickening unit in the central process control system of the sewage treatment plant. Decentralised monitoring and control of the polymer preparation unit is therefore possible.

With the installation of the new mechanical sludge thickening system, both the operational reliability and the throughput capacity were extended and optimised significantly. In addition, it was possible to reduce the consumption of flocculant aids significantly and simultaneously increase the end dry material content of the thick sludge to 6 – 8%.

The new mechanical sludge thickening system will make a significant contribution to reducing the energy and operating material costs of Flensburg sewage treatment plant in future – thanks also to the polymer preparation unit supplied by **sera**.



SERVICE



The Dinkelacker family brewery, founded in Stuttgart in 1888, has been using sera dosing pumps for a hygienically perfect brewing process for decades. The R413KM was used to dose chemicals in the cleaning process for over 30 years – but the wear and its age could no longer be ignored and a replacement was essential. As this pump was removed from our product range several years ago, our Service department recommended reconditioning the old pump as a solution.

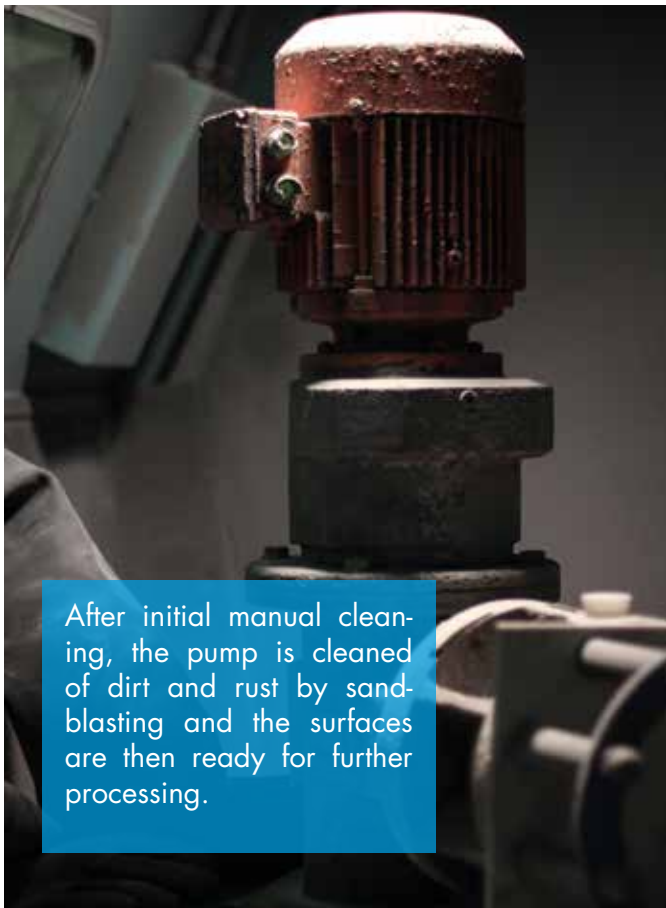

After initial manual cleaning, the pump is cleaned of dirt and rust by sandblasting and the surfaces are then ready for further processing.





All of the parts are painted in our paint shop – the re-milled base ring and the reconditioned motor.



Following assembly of the reconditioned and new components, the R413KM is put through its paces in our test facility.



Four days of maintenance work and the expertise of the **sera** Service colleagues have turned an aging dosing pump into a new, fully functioning pump which is now doing its job again in the Dinkelacker family brewery – for hygienic cleaning and maximum product reliability.

HIGHEST QUALITY IS OUR STANDARD

Every day we face up to new challenges – always with a professional and extremely careful approach. sera has set itself the goal of manufacturing products of the highest quality and using appropriate processes to do so. And our customers have every right to expect the best of us. From the management and the employees at all levels of the company through to our suppliers, everyone involved is aware of this huge responsibility – because our goal is always to meet these high standards.

Quality is the basis for effective collaboration, the foundation for a well thought-out product – and it is the prerequisite for an effective process. Quality is therefore evident in all areas at sera: in the work of our employees, in our technical development, and in the function and assembly of our systems.

In order to meet this high standard at all times, team training, participation of our company in various committees and ongoing control of our products, materials and production through certification is all part

of our day-to-day business. As we are always putting our products to the test and developing them further, they are a by-word for environmental awareness, reliability, sustainability, efficiency and state-of-the-art technology – and therefore for demonstrably high quality overall!

Our quality testing and control, which is independent from production and the product lines, ensures that the materials processed, the components, assemblies and products produced and the services we offer always meet the highest standards. Our quality assurance monitors compliance with national and international regulations, statutory and contractual provisions and the guidelines and regulations that we put in place.

In order to ensure smooth interaction of quality and occupational safety management, we have brought these two areas together to form an Integrated Management System (IMS).



Our IMS is based on the principles of the sera Group in relation to quality, environmental protection and occupational safety. It meets the requirements of the internationally recognised standards and regulations, such as DIN EN ISO 9001:2015, under which we were one of the first companies to be certified. We also take account of statutory regulations and, in special cases, specific requirements of a sector, such as energy technology or the food and pharmaceuticals industries.

In this way, we are able to offer you efficient solutions that meet all standards, fit perfectly with existing systems and provide a long service life and reliable operation of your plant.

BASF
The Chemical Company

OVIVO Worldwide Experts
in Water Treatment



Conaqua



KRONOS

EVONIK
INDUSTRIES

GEA

DOW

LIKUSTA
environmental solutions

AREVA

evog
WATER TECH

Stadtwerke
WINTERBERG

W Weber
Kunststofftechnik

sas

WASSER BAU GESELLSCHAFT

WBG

vez
environnement
Degrémont

VEOLIA





OUR REFERENCES AT A GLANCE

sera dosing technology with high-quality metering pumps and dosing systems has been used for more than 70 years in a wide range of industries all over the world. The products create added value every day and provide high-quality results for the consumer. We offer you:



High-quality pumps, dosing units and systems

We offer you a comprehensive portfolio of reliable, durable and precise metering pumps for output capacities from 0.4 l/h to 1,450 l/h at pressures of up to 300 bar. Or choose from a wide range of feeding pumps with a pump capacity of up to 3,100 l/h.



A wide variety of models and materials

For over 70 years, we have stood for experience and expertise. We are able to modify your designs and provide the models you require quickly and flexibly.



Individual customised solutions

Developing and implementing customised solutions perfectly tailored to meet the needs of each specific application.



Economical solutions

Short delivery times and high availability at a great price without compromising on performance. Sophisticated product lines for a wide range of applications with extensive upgrading options and accessories.



Maintenance and service

Our services include maintenance and repair services, providing spare parts, assembly and installation, technical support, and customer training.



Fittings and accessories

We provide an extensive range of fittings and accessories, thanks to our dosing systems and metering pumps. Feel free to contact us.



CUSTOM SOLUTIONS FOR YOUR APPLICATIONS

Often standard dosing systems cannot adequately meet specific requirements.

Developing customised solutions is one of our strengths. Our application engineers work with you to develop your very own customised solution for your specific application.

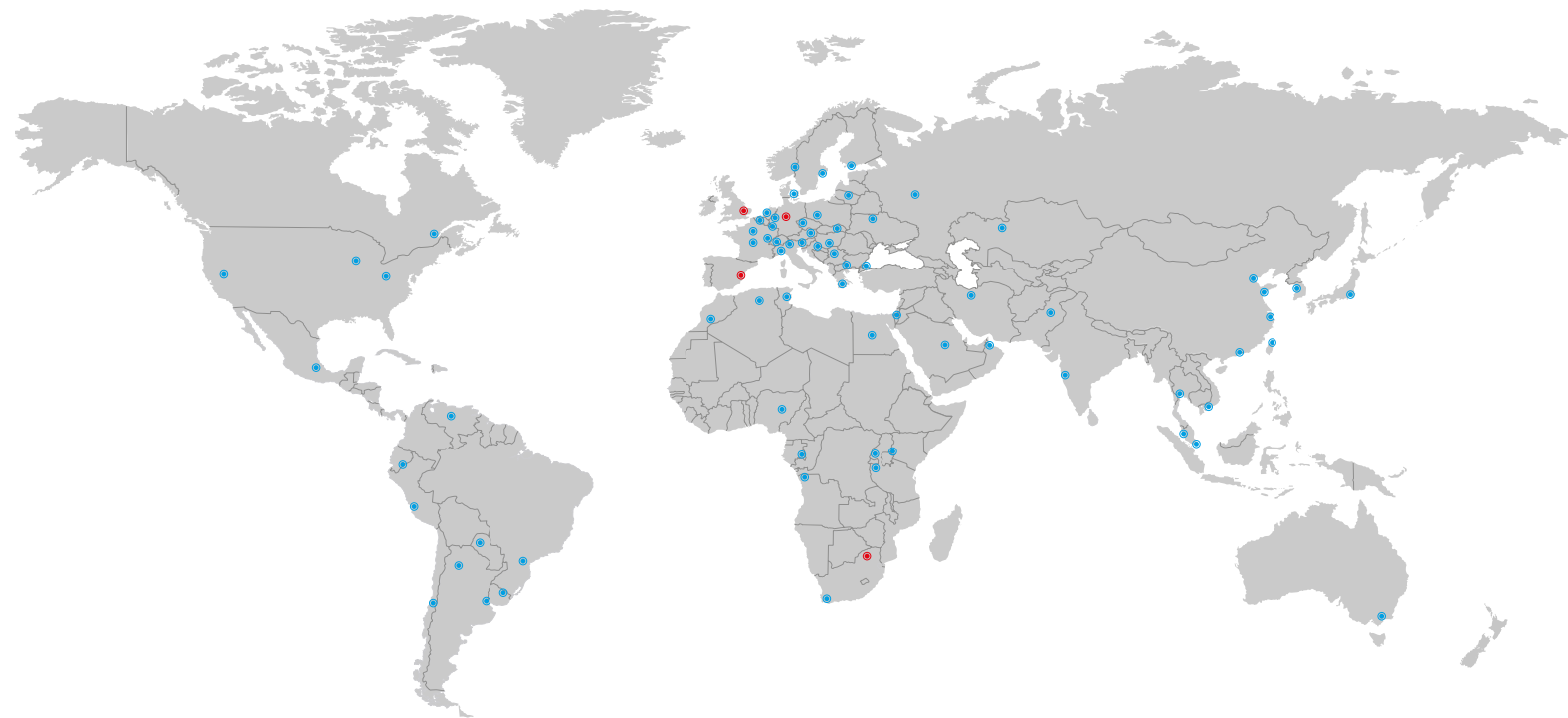

WORKING FOR YOU WORLDWIDE

Your sera contacts

With headquarters in Germany and subsidiaries in the UK, Spain and South Africa, as well as a global sales and service network with over 30 partners in more than 80 countries all over the world, **sera** guarantees the best possible customer care on site.

sera ProDos GmbH
sera-Straße 1
34376 Immenhausen
Germany

Tel.: +49 5673 999-02
Fax: +49 5673 999-03

info-prodos@sera-web.com
www.sera-web.com

sera ProDos UK Ltd.
Axon 2, Commerce Road,
Lynchwood
Peterborough, PE2 6LR
UK

Tel.: +44 1733 396040
Fax: +44 1733 396050

sales.uk@sera-web.com
www.sera-web.com

sera ProDos SA (PTY) Ltd.
Unit 3-4, Airborne Park
Cnr Empire & Taljaard Str
Bartletts, Boksburg, 1459
Gauteng
South Africa
Tel.: +27 11 397 5120
Fax: +27 11 397 5502

sales.za@sera-web.com
www.sera-web.com

sera ProDos S.L.
Calle Cocentaina n°8,
03420, Castalla (Alicante)
Spain

Mobile: +34 610 418898

sales.es@sera-web.com
www.sera-web.com

