

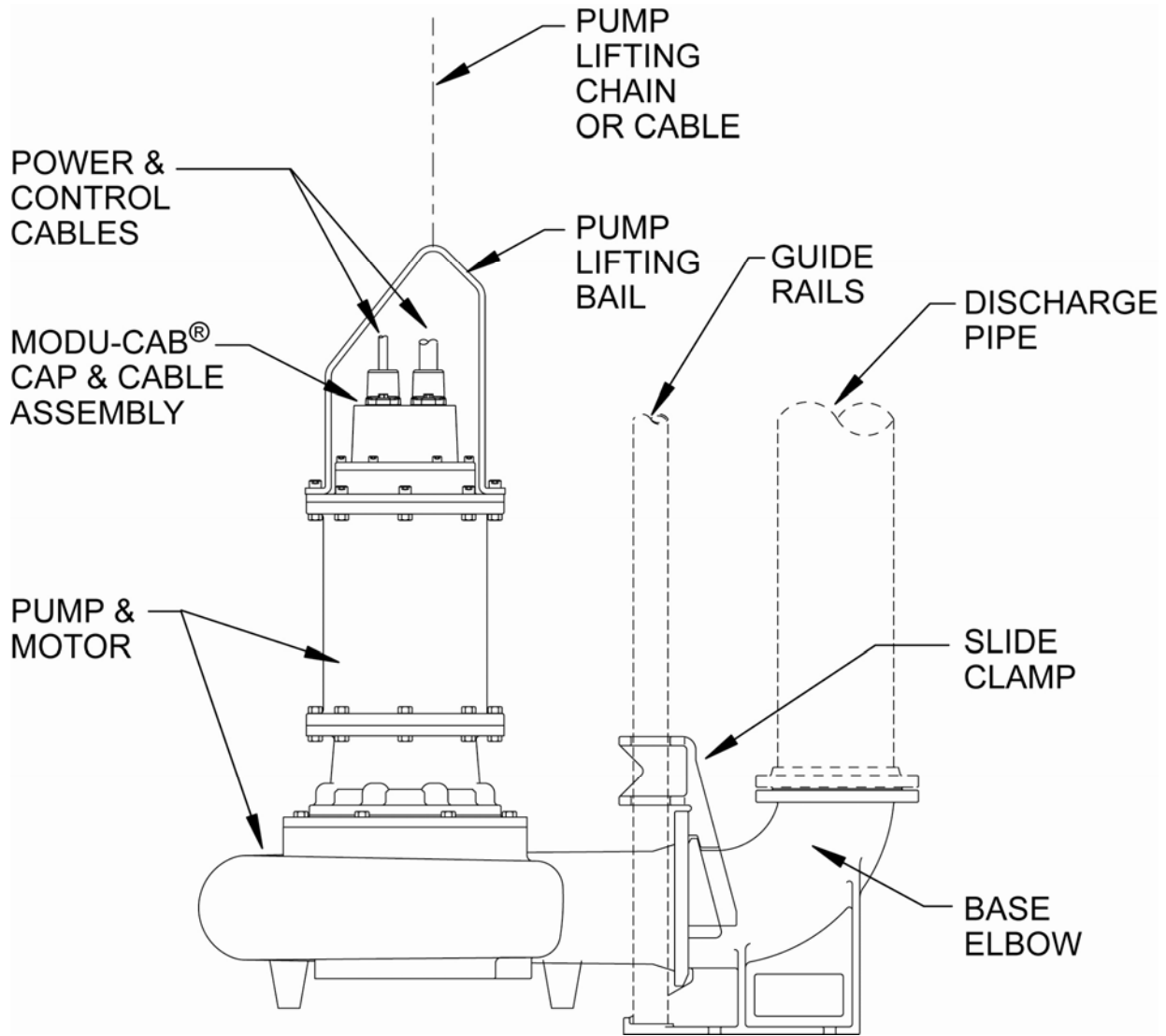

# SUBMERSIBLE PUMPS

## INSTALLATION, OPERATION AND MAINTENANCE MANUAL

YEOMANS SERIES 9100 SUBMERSIBLE PUMPS  
WITH SINGLE RAIL QUICK LIFT OR  
DUAL RAIL EASY-LIFT® GUIDE RAIL SYSTEM



### TYPICAL PUMP INSTALLATION

YEOMANS PUMP  
3905 ENTERPRISE COURT  
AURORA, IL 60504 USA

# Table of Contents

## SECTION A-GENERAL

1) Purpose and Importance of Manual .....	3
2) Special Precautions.....	3
3) Receiving Inspection-Shortages.....	3
4) Preservation and Storage.....	3
5) Handling.....	3
6) CAUTION.....	3
7) Motor and Mechanical Seals.....	3
8) Electrical Leads.....	4
9) Controls.....	4
10) Accessories.....	4

## SECTION B-INSTALLATION

### PUMP ONLY (Without Quick Lift)

1) Location.....	5
2)Checking Rotation.....	5
3) Setting and Alignment.....	5
4) Piping.....	5

### PUMP WITH SINGLE RAIL QUICK LIFT

1) Location.....	6
2) Checking Rotation.....	6
3) Foundation and Guide Rail.....	6
4) Piping.....	6

DRAWING - QUICK LIFT ASSEMBLY SINGLE RAIL.....	7
--	---

### PUMP WITH DUAL RAIL EASY LIFT

1) Location.....	8
2) Checking Rotation.....	8
3) Foundation and Guide Pipes.....	8
4) Piping.....	8

DRAWING - EASY LIFT ASSEMBLY.....	9
-----------------------------------	---

## SECTION C-OPERATION

PUMP ONLY.....	10
----------------	----

SINGLE AND DUAL RAIL PUMPS.....	11
---------------------------------	----

<b>SECTION D-MAINTENANCE.....</b>	<b>12</b>
-----------------------------------	-----------

SECTION E-DISASSEMBLY AND REASSEMBLY.....	13
---	----

DRAWING -9100 SUBMERSIBLE PUMPS-ALL MODELS.....	14
---	----

<b>SECTION F-TROUBLESHOOTING.....</b>	<b>15-17</b>
---------------------------------------	--------------

## SECTION A-GENERAL

### 1) Purpose and Importance of Manual

Your YEOMANS Submersible Pump is built to give trouble-free service. This manual is intended to instruct in its proper installation, operation and maintenance. Strict compliance with these instructions will insure reliable performance in wastewater service. Keep this manual handy for ready reference.

### 2) Special Precautions

YEOMANS cannot be responsible for any damage resulting from failure to comply with these instructions. This pump is not to be operated at conditions or with liquids other than those stated in the original order acknowledgment without written permission from YEOMANS CHICAGO CORPORATION.

### 3) Receiving Inspection--Shortages

Upon receiving shipment make sure that no damage occurred in transit and that shipment complies with the bill-of-lading. Make note of damage or shortage on both receipt and freight bill. Claims should be made to the transportation company within five (5) days.

### 4) Preservation and Storage

The pumps are shipped with adequate protection for transport in covered trucks, covered storage at job site, and for a limited time between installations and start up. YEOMANS CHICAGO CORPORATION should be notified if it is anticipated that the equipment will be exposed to extreme or extended storage conditions prior to installation, so that shipment can be given special protection.

### 5) Handling

The pump and other vulnerable parts which may be subject to damage are provided with eye bolts or lifting lugs. Be sure to use these, and above all, **DO NOT LIFT PUMP BY THE ELECTRICAL POWER CABLE.**

### 6) **CAUTION**

***BE CAREFUL NOT TO HAVE HANDS, FEET, CLOTHING OR OTHER OBJECTS IN OR NEAR THE PUMP SUCTION OPENING WHEN POWER IS ON!***

### 7) Motor and Mechanical Seals

The motor is a "dry" type as opposed to one with oil filled stator housing. The only pump bearings are those in the motor and these ball bearings are prelubricated for at least five years of service before requiring attention. The tandem mechanical seals are housed in an oil filled reservoir. This assures lubrication of the seal faces even when the motor is operated in air. The thermal protectors are automatic reset type for use in a normally closed circuit and are connected in series with the holding coil of the magnetic starter. The oil filled seal reservoir has two electrodes, which are connected to a moisture sensing circuit, which will detect any water that may leak into the reservoir. This will indicate a faulty outer (lower) mechanical seal.

### 8) Electrical Leads

All leads are epoxy sealed to the cable connector. One cable (the larger) has the power leads and ground wire and the other contains the thermal protector and moisture detector leads. Check the current and voltage characteristics of the motor nameplate with those of the control panel. If not in agreement, notify YEOMANS CHICAGO CORPORATION immediately. The electrical leads must be caulked at the junction box to prevent escaping gases from entering the control panel.

## 9) Controls

The control consists of a motor control panel plus liquid level sensors, alarms, and many options. The controls must comply with different specifications, the National Electrical Code, and building codes, which vary with each location, hence, must be detailed separately for each individual installation. The main control panel is generally located outside of the hazardous area and can be NEMA 3R.

## 10) Accessories

The most common accessories are the quick lift winch and pit access doors. There are many variations in door construction to cover different codes and specifications so; here again, they will be detailed separately. Where necessary, aluminum doors are available; they are non-sparking and light in weight. The quick lift winch is optional and is installed in a sleeve, which is set in the pit deck allowing it to swivel into position.

## SECTION B-INSTALLATION

### PUMP ONLY (Free Standing / Without Guiderail System)

#### 1) Location

When selecting a location for the pump, be sure to provide sufficient floor space for inspection and servicing. Also, adequate headroom for installing and removing the pump is required. Therefore, avoid installation near corners or under stairways.

#### 2) Checking Rotation

It will be necessary to check the rotation of the motor and pump impeller before installing the unit into the basin.

**CAUTION: BE CAREFUL NOT TO HAVE HANDS, FEET, CLOTHING, OR OTHER OBJECTS IN OR NEAR THE PUMP SUCTION OPENING WHEN THE POWER IS ON!**

The motor leads should be marked, or the starter diagram located inside the starter should be marked, or both, so that the connections can be broken and remade with accuracy. It is important that the pump rotate in the direction for which it was designed. Lay the pump on its side and connect the motor lead to the permanent source of power. Quickly turn the power on and off to get the impeller spinning. Examine the impeller through the suction opening. It should be turning counterclockwise. If not, change any two of the motor leads and recheck. As soon as the motor is rotating in a counterclockwise direction, mark the leads and diagram as mentioned above. The above instructions apply to three phase motors. Single phase motors cannot be reversed in this manner, and the rotation is factory checked. Consult factory *if* rotation reversal is required for single-phase motors.

#### 3) Setting and Alignment

Before setting the pump into the basin, clean the basin and all incoming lines of any material left after project construction and clean-up operations to eliminate destructive material which could damage the pump or motor. The pump should be placed so the feet are set securely on the bottom of the sump and pump is plumb. The pump should be so located in the pit that the discharge pipe will not prevent the proper seating and location of the cover. The control switches should be so located that the rush of incoming water will not cause the control switches to function incorrectly.

**CAUTION: DO NOT LOWER PUMP BY THE ELECTRICAL CABLES.**

#### 4) Piping

In most cases the discharge piping arrangement has been established, however, there are several rules to follow. The pipe size should be no smaller than that of the pump discharge flange. Gate and check valves should be provided in each discharge pipe with the check valve placed between the gate valve and the pump. The valves may be either inside or outside the pit. **THE FIELD INSTALLED DISCHARGE PIPING MUST BE SUPPORTED INDEPENDENTLY OF THE PUMP.** Before connecting the pump flange, make sure the flanges meet exactly and do not have to be forced into position.

## PUMP WITH SINGLE RAIL QUICK LIFT

### 1) Location

In most cases the pit size, pump elevation, piping arrangement, access door location, and other features have been established and are shown on an installation drawing (refer to construction installation drawing). The pump or pumps should be located in the pit on opposite side from the influent opening.

### 2) Checking Rotation

It will be necessary to check the rotation of the motor and pump impeller before installing the unit into the basin.  
**CAUTION: BE CAREFUL NOT TO HAVE HANDS, FEET, CLOTHING OR OTHER OBJECTS IN OR NEAR THE PUMP SUCTION OPENING WHEN THE POWER IS ON!**

The motor leads should be marked, or the starter diagram location inside the starter should be marked, or both, so that the connections can be broken and remade with accuracy. It is important that the pump rotates in the direction for which it was designed. Lay the pump on its side and connect the motor lead to the permanent source of power. Quickly turn the power on and off to get the impeller spinning. Examine the impeller through the suction opening. It should be turning counterclockwise. If not, change any two of the motor leads and recheck. As soon as the motor is rotating in a counterclockwise direction, mark the leads and diagram as mentioned above. The above instructions apply to three phase motors. Single-phase motors cannot be reversed in this manner, and rotation is factory checked. If rotation reversal is required for single-phase motors, consult the factory.

### 3) Foundation and Guide Rail

With the quick lift arrangement the pump is supported by the base elbow, which also supports the discharge piping. The pit floor should be designed to cant' the load of the entire assembly of pump, base elbow, guide rails, and discharge piping. The foundation bolts for the base elbow are located off the clear opening in the pit cover as shown in the installation drawing referenced in Paragraph 1) above and should be long enough to accommodate 1" of grout under the foot of the base elbow. The base elbow should be shimmed from the rough concrete floor until the horizontal pipe flange is level in both directions. Then grout the base, and allow the grout to harden before tightening the foundation bolt nuts. Referring to Figure 1 (Drawing 103785) the lower end of the guide rail is inserted into the base elbow. The upper end of the guide rail is then attached to the pit opening; cover angle, or whatever method has been provided. (This attachment varies with installations and is the responsibility of the customer.) The rail has lateral support by means of pipe straps connected to the discharge pipe. Again referring to Figure 1, slide plate (part 5) is shipped with two shoes (part 9) attached. Insert the neoprene jam washer (part 4) as shown, then bolt the assembly to the pump discharge flange.

### 4) Piping

In most cases, the discharge piping arrangement has been established and a typical arrangement is shown on the installation drawing; however, there are several rules to follow. The pipe size should be no smaller than that of the base elbow. Gate and check valves should be provided in each discharge pipe with the check valve placed between the gate valve and the pump. The valves may be either inside or outside the pit. The weight of the piping is supported on the base elbow but long (10' or more) vertical sections may require lateral support from the pit wall.

**QUICK LIFT ASSEMBLY  
SINGLE RAIL  
(Drawing No. 103785)**

<b>COMPONENT &amp; MATERIALS LIST</b>				
<b>ITEM</b>	<b>QTY</b>	<b>DESCRIPTIVE NAME</b>	<b>STANDARD MATERIAL</b>	<b>OPTIONS</b>
1	1	Submersible Pump & Motor Assy.	Cast Iron	
2	8	Hex. Head. Cap Screw	Stainless Steel	
3	8	Flat Washer	Stainless Steel	
4	1	Jam Washer	Neoprene	
5	1	Slide Plate - Pump To Guide Rail	Ductile Iron	
6	1	Base Elbow	Cast Iron	
7	4	Hex. Head. Cap Screw	Stainless Steel	
8	4	Lockwasher - Spring Type	Stainless Steel	
9	2	Guide Shoe - Guide Rail	Cast Iron	
10	1	Guide Rail - Angle	Steel	Galv. Steel ; S.S.

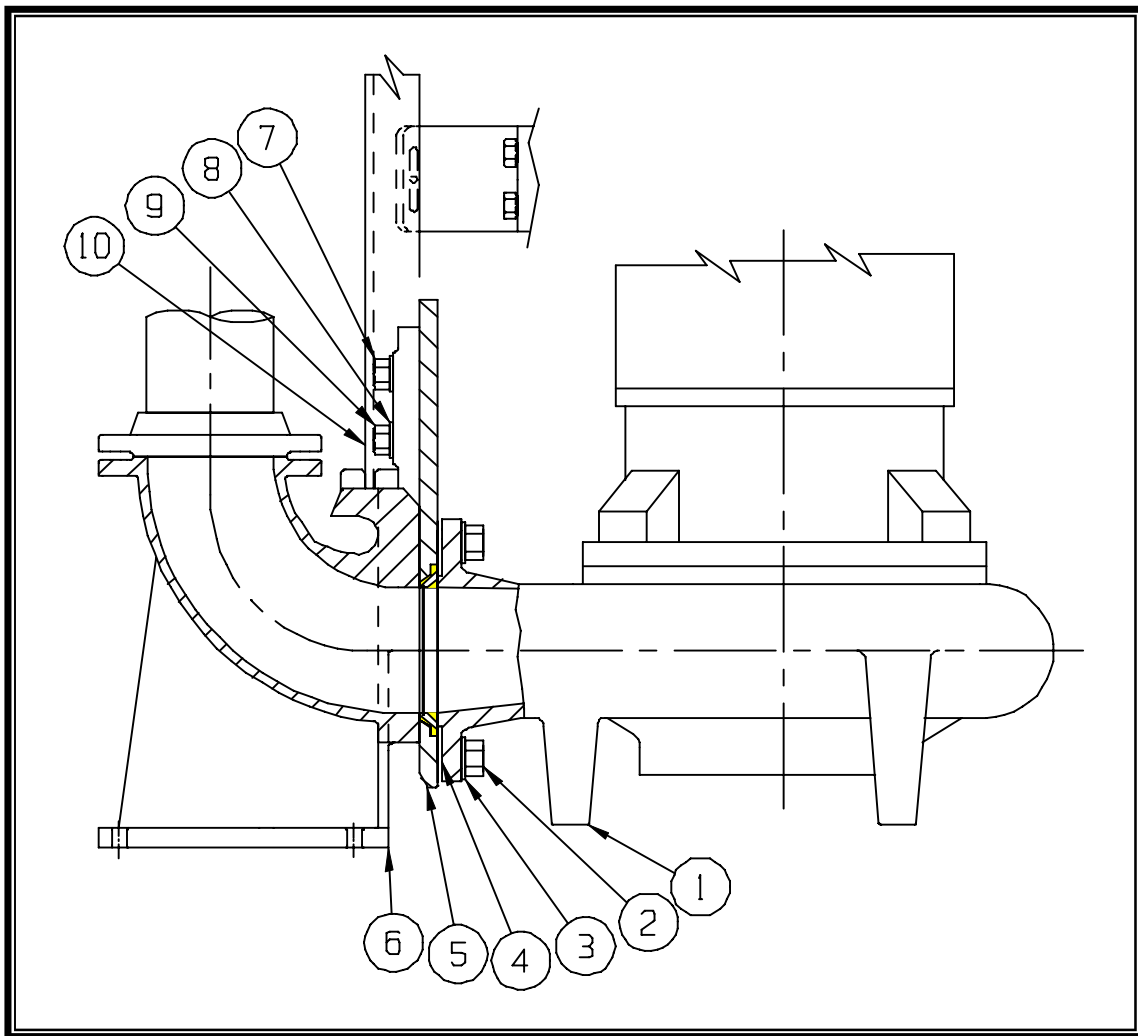

**FIGURE No. 1**

## PUMP WITH DUAL RAIL EASY-LIFT®

### 1) Location

In most cases the pit size, pump elevation, piping arrangement, access door location, and other features have been established and are shown on an installation drawing. (Refer to construction installation drawing.) The pump or pumps should be located in the pit on the opposite side from the influent opening.

### 2) Checking Rotation

It will be necessary to check the rotation of the motor and pump impeller before installing the unit into the basin.  
**CAUTION: BE CAREFUL NOT TO HAVE HANDS, FEET, CLOTHING, OR OTHER OBJECTS IN OR NEAR THE PUMP SUCTION OPENING WHEN THE POWER IS ON!**

The motor leads should be marked, or the starter diagram located inside the starter should be marked, or both, so that the connections can be broken and remade with accuracy. It is important that the pump rotates in the direction for which it was designed. Lay the pump on its side and connect the motor lead to the permanent source of power. Quickly turn the power on and off to get the impeller spinning. Examine the impeller through the suction opening. It should be turning counterclockwise. If not, change any two of the motor leads and recheck. As soon as the motor is rotating in a counterclockwise direction, mark the leads and diagram as mentioned above. The above instructions apply to three phase motors. Single-phase motors cannot be reversed in this manner, and the rotation is factory checked. If rotation reversal is required for single-phase motors, consult the factory.

### 3) Foundation and Guide Pipes

With the easy lift arrangement the pump is supported by the base elbow, which also supports the discharge piping. The pit floor should be designed to carry the weight of the entire assembly of pump, base elbow, guide pipes, and discharge piping. The foundation bolts for the base elbow are located off the clear opening in the pit cover as shown on the installation drawing referenced in Paragraph 1) above and should be long enough to accommodate 1" of grout under the foot of the elbow. The base elbow should be shimmed from the rough concrete floor until the horizontal pipe flange is level in both directions. Then grout the base and allow the grout to harden before tightening the foundation bolt nuts. Referring to Figure 3, slide the two guide pipes over their pins in the base elbow. At the top of the guide pipes, install the pipe spacer with the plugs entering the pipes. For pits deeper than 8 feet, special intermediate spacers may be provided to laterally support the guide pipes to the discharge pipe. Then the upper ends of the guide pipes are attached to the floor plate cover angle, or whatever method has been provided. (This attachment varies with installations and is the responsibility of the customer.)

### 4) Piping

In most cases, the discharge piping arrangement has been established and a typical arrangement is shown on the installation drawing; however, there are several rules to follow. The pipe size should be no smaller than that of the base elbow. Gate and check valves should be provided in each discharge pipe with the check valve placed between the gate valve and the pump. The valves may be either inside or outside the pit. The base elbow supports the weight of the piping but long (10' or more) vertical sections may require lateral bracing from the pit wall.



**EASY-LIFT® ASSEMBLY  
DUAL RAIL  
(Drawing No. 111932)**

<b>COMPONENT &amp; MATERIALS LIST</b>				
<b>ITEM</b>	<b>QTY</b>	<b>DESCRIPTION NAME</b>	<b>STANDARD MATERIAL</b>	<b>OPTIONS</b>
1	1	Submersible Pump & Motor Assembly	Cast Iron	
2	1	Easy Lift Stationary Elbow	Cast Iron	
3	1	Easy Lift Slide Clamp.	Cast Iron	Bronze / Stainless
4	4	Hex Head Cap Screws	Stainless Steel	
5	4	Lockwasher Spring Type	Stainless Steel	

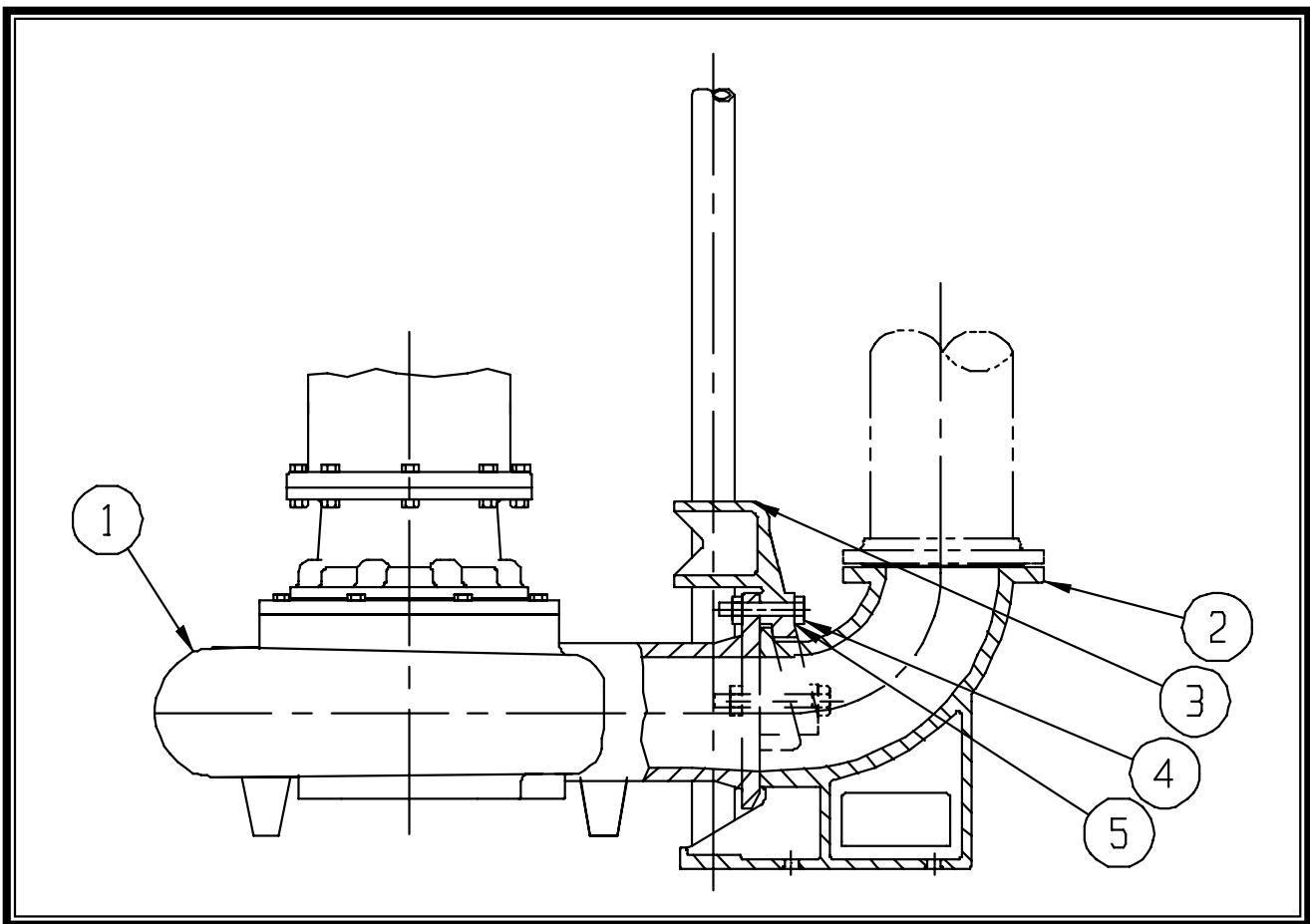

**FIGURE No. 3**

## SECTION C - OPERATION

### **PUMP ONLY**

Before making electrical connections check that the impeller can be turned freely by hand. This can be done by reaching into the suction opening. There is a certain drag from the seals so the impeller will not spin, but should be turned at least two revolutions. If it cannot be turned, correct the problem before starting. (Refer to TROUBLESHOOTING-Section F).

Check the direction of rotation by connecting leads to the starter (see wiring diagram) and jogging in manual mode. The rotation should be counterclockwise as viewed through the pump suction. This can be observed by flashlight through the suction opening. Be cautious with hands or flashlight around the opening. If rotation is incorrect, switch any two motor leads and recheck. This procedure is only required on three phase motors. Single-phase motors operate in only one direction and were checked at the factory. Consult factory if rotation reversal is required on single-phase motors. Mark each electrical lead to assure the correct rotation is maintained if leads are disconnected at any time. Now, before lowering the pump into the pit and before filling with fluid, the pit should be cleaned of all construction debris such as chunks of wood, metal, or concrete. Also, the influent pipe should be checked for similar debris. Also check the moisture sensing circuit for the mechanical seal by means of the test button or an ohmmeter. If the light turns on, or the measured resistance exceeds 300,000 ohms, the circuit is working; if not, correct before proceeding. (Refer to motor instruction manual.)

After installation of the pump is complete, open the pump discharge valve or valves and open the influent valve allowing fluid into the pit. When the liquid level is above the motor, start each pump separately and take current readings in each phase. If these readings are substantially less than the nameplate values, the pump may be air bound. Jog the motor several times until better agreement is reached. Also, observe for any unusual vibration. If all seems normal, switch selector to automatic and note that the pump starts on high level and stops on low level; or, in the case of a duplex station, that the pumps alternate properly. Observe pumps for the first few hours of operation with special attention to the moisture sensing device and the thermal overload relays. Pump may be shut down without closing any valves, unless there are no check valves. In this case, the discharge gate valve must be closed before stopping the pump in order to prevent excessive back flow through the pump. YEOMANS CHICAGO CORPORATION strongly recommends the use of check valves for unattended pump stations with automatic control systems. If the pump is to be serviced, be sure the power is off and the motor safety switch is padlocked to prevent another person from turning it on.

## SINGLE AND DUAL RAIL PUMPS

Before making electrical connections check that the impeller can be turned freely by hand. This can be done by reaching into the suction opening. There is a certain drag from the seals so the impeller will not spin, but should be turned at least two revolutions. If it cannot be turned, correct the problem before starting. (Refer to TROUBLESHOOTING-Section F).

Check the direction of rotation by connecting leads to the starter (see wiring diagram) and jogging in manual mode. The rotation should be counterclockwise as viewed through the pump suction. This can be observed by flashlight through the suction opening. Be cautious with hands or flashlight around the opening. If rotation is incorrect, switch any two motor leads and recheck. This procedure is only required on three phase motors. Single-phase motors operate in only one direction and were checked at the factory. Consult factory if rotation reversal is required on single-phase motors. Mark each electrical lead to assure the correct rotation is maintained if leads are disconnected at any time. Now, before lowering the pump into the pit and before filling with fluid, the pit should be cleaned of all construction debris such as chunks of wood, metal, or concrete. Also, the influent pipe should be checked for similar debris. Also check the moisture sensing circuit for the mechanical seal by means of the test button or an ohmmeter. If the light turns on, or the measured resistance exceeds 300,000 ohms, the circuit is working; if not, correct before proceeding. (Refer to motor instruction manual.)

Attach the lifting chain to the motor and lift it in to a balanced position over the guide rail (pipes). As the pump is lowered, make sure that the slide plate and shoes properly engage the upper end of the guide rail, or slide plate properly engages the upper ends of the guide pipes (whichever is applicable). Lower the pump into operating position making sure that the electrical cables are not tangled. This would cause a hang-up and damage to the cables. Enter the pit to make certain that the pump is in position, then mark a link of the chain at the edge of the cover or door frame. This will insure proper positioning of the pump in subsequent lowerings. The lower end of the chain remains on the motor and the upper end is attached to a hook at the cover. The pump is removed by a reverse procedure to the above. Repeat this procedure to insure proper subsequent seating.

After installation of the pump is complete, open the pump discharge valve or valves and open the influent valve allowing fluid into the pit. When the liquid level is above the motor, start each pump separately and take current readings in each phase. If these readings are substantially less than the nameplate values, the pump may be air bound. Jog the motor several times until better agreement is reached. Also, observe for any unusual vibration. If all seems normal, switch selector to automatic and note that the pump starts on high level and stops on low level; or, in the case of a duplex station, that the pumps alternate properly. Observe pumps for the first few hours of operation with special attention to the moisture sensing device and the thermal overload relays. Pump may be shut down without closing any valves, unless there are no check valves. In this case, the discharge gate valve must be closed before stopping the pump in order to prevent excessive back flow through the pump. YEOMANS CHICAGO CORPORATION strongly recommends the use of check valves for unattended pump stations with automatic control systems. If the pump is to be serviced, be sure the power is off and the motor safety switch is padlocked to prevent another person from turning it on.

## SECTION D-MAINTENANCE

Preventative maintenance should be carried out per the following schedule:

<b>Frequency</b>	<b>Work Required</b>
Every Month	<p>a) Check moisture sensor circuit by means of the test button on the relay, or by measuring the resistance of the moisture sensing circuit. Resistance should be no less than 300,000 ohms.</p> <p>b) On duplex unit and if equipped with ET meters, check to see if elapsed time is balanced between the two pumps. Any gross unbalance indicates a defective unit, float switch, or control.</p> <p>c) Inspect float switches for any material that might be lodged and impairing their operation.</p>
Every Two Years	<p>a) Drain, flush, and refill the seal chamber with new oil. Refer to Motor Instructions.</p> <p>b) Inspect for any signs of water intrusion in the motor seal chamber and seal cap chamber. On the seal chamber this may be accomplished by inspection of the oil that was drained. The seal cap chamber should be visually inspected for moisture.</p> <p>c) Inspect power cable for any signs of abrasion or damage that might affect the integrity of the outer jacketing.</p> <p>d) Inspect impeller and casing wear rings) for unusual wear. Replace parts if required.</p>
Every Five Years	<p>A complete overhaul by a competent service repair shop should include the following:</p> <p>a) Completely dismantle the pump and motor.</p> <p>b) Clean and inspect all parts.</p> <p>c) Inspect all mechanical seal parts.</p> <p>d) Replace worn or damaged parts.</p> <p>e) Replace ball bearings regardless of condition.</p> <p>f) Replace all "O" rings and gaskets.</p> <p>g) Inspect motor stator for any sign of abrasion and burned spots on the winding. Conduct an insulation test. Refer to the factory for values.</p>

**NOTE: UNDER ADVERSE CONDITIONS INCREASE FREQUENCY OF CHECKS.**

## SECTION E-DISASSEMBLY AND REASSEMBLY

Completely remove pump from the pit. Padlock motor safety switch and mark electrical leads to maintain correct rotation. Disconnect pump cable leads from control panel.

Referring to Figure 4 (Drawing 103783-B1), remove cap screws (part 2) and lift motor with impeller out of volute. If gasket is destroyed, note its thickness for replacement. Note that an adapter plate (part 4) is shown. This may or may not be on your pump depending on the size of the motor. Lay this assembly on its side on a bench. For the applicable specific motor frame, remove impeller cap screw or heavy hex nut and washer (part 12). Pull the impeller off the motor shaft using a wheel puller or similar tool. Remove impeller key (part 13). If pump has a motor adapter plate, generally there is no need to remove it.

On pump models equipped with polyurethane casing wear ring (See Illustration A for details and list of applicable models), ring may be removed by severing in half (semi-circle) and extracting. Replacement ring can then be drive fitted into place. Optional impeller wear ring (part 75) can also be removed by cutting off impeller eye outside diameter. Replacement impeller wear ring can be driven onto impeller eye outside diameter. (Slightly heating the wear ring may facilitate reinstallation.) All other models equipped with either casing wear ring (part 76) and/or impeller wear ring (part 75) are disassembled by removing machine screw (part 77). New replacement screws must be used and "loctited" in place upon reassembly.

For the disassembly of the motor, refer to specific motor instruction manual. Note that stator repairs can be made with only partial motor disassembly. However, if complete disassembly is required, follow complete procedure in the motor instruction manual. After the motor is repaired and reassembled, again place it on its side on a bench. Assemble the pump in reverse order of disassembly.

# SERIES 9100 SUBMERSIBLE PUMPS – ALL MODELS

ITEM	DESCRIPTIVE NAME	MAT'L
1	MOTOR	YCC
2	HEX HD CAP SCREW - MTR TO UNIT	STN STL
3	GASKET - MTR ADAPTER PLATE - (WHEN REQ'D)	NEOPRENE
4	ADAPTER PLATE - MTR TO PUMP (WHEN REQ'D)	CAST IRON
5	GASKET - MTR/ADAPTER PLATE/VOLUTE	NEOPRENE
6	SOCKET HD CAP SCREW - ADPTR PLT TO PUMP	STN STL
7	VOLUTE (DISCHARGE CASING)	CAST IRON
8	IMPELLER	CAST IRON
12	IMPELLER WASHER	STN STL
12A	IMPELLER LOCK SCREW WITH NYLON INSERT	STN STL
12B	SPRING LOCKWASHER - IMPELLER	STN STL
12C	HEAVY HEX NUT - IMPELLER	STN STL
13	KEY - IMPELLER DRIVE	STN STL
14	SPACER BUSHING - IMPELLER (WHEN REQ'D)	STN STEEL
75	WEARING RING - IMPELLER	STN STL
76	WEARING RING - CASING	POLY
76A	WEARING RING - CASING	STN STL
77	FLAT HD MACHINE SCREW - W/R LOCKING	STN STL
	REPAIR KIT	

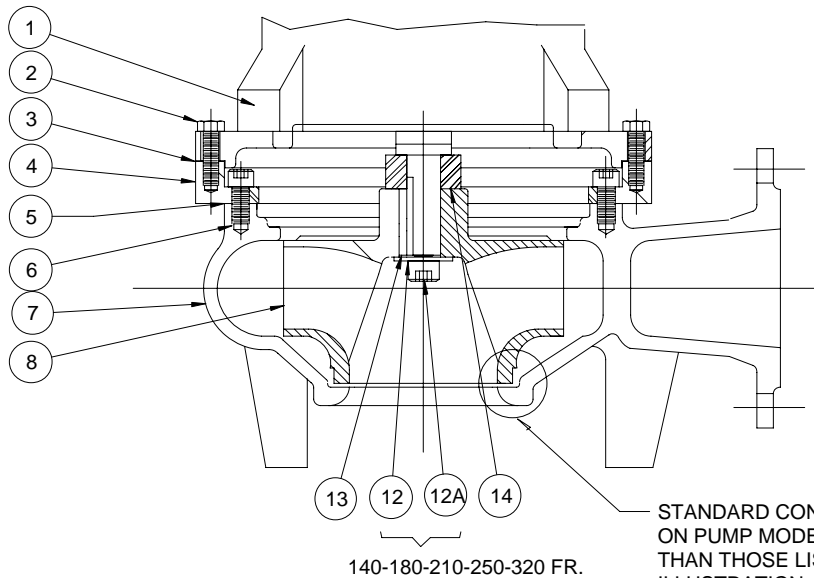
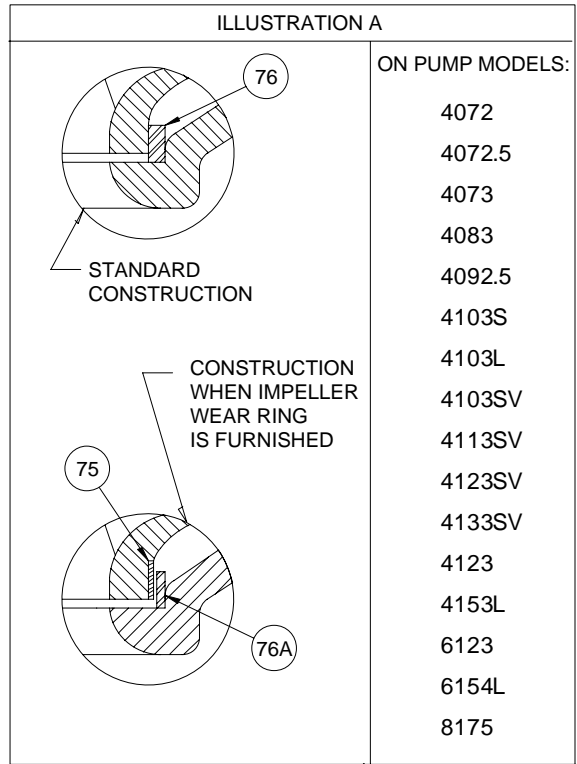

103783-B1\_DWP

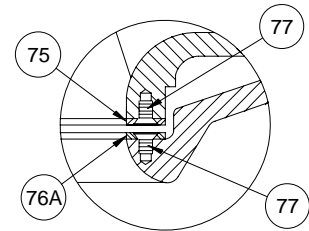

CONSTRUCTION WHEN WEAR  
RINGS ARE FURNISHED ON PUMP  
MODELS OTHER THAN THOSE  
LISTED ON ILLUSTRATION A

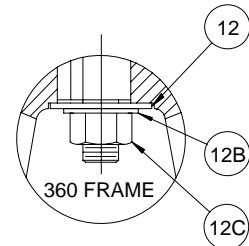

4/21/05

**FIGURE No. 4**

## SECTION F-TROUBLESHOOTING

**CAUTION:** Motor section of this pump is sealed against outside contamination. Before inspecting pump, disconnect all electrical power to pump motor and accessories.

PROBLEM	PROBABLE CAUSES	CORRECTIVE ACTION
Pump will not run	Improper wiring.	Check wiring.
a) Manual operation	Low voltage.	Check voltage at contactor, starter or receptacle to make certain it coincides with nameplate voltage.
	Blown fuse, broken or loose electrical connection.	Check fuses, circuit breakers, and electrical connections.
	Power cord insulation damaged.	Replace power cord.
	Power cord may be open or grounded.	Resistance between hot leads should be zero. Resistance between hot lead and ground (green) should be infinite.
	Pump impeller locked.	Check amps drawn by motor. If reading is 2 or more times maximum amps listed in specification table, impeller is locked, motor bearings frozen, or shaft is bent. Remove pump casing for inspection and cleaning.
	Motor overload protection tripped.	Allow overload protectors to cool then press re-set button. Recheck amps. If current is present but pump does not run, locked impeller condition exists.
b) Automatic operation.	Loose connection in level control wiring.	Check control panel wiring.
NOTE: Before trouble-shooting automatic control check to see that pump operates on manual control. If it does, automatic controls are at fault. If not, fault is in pump or power supply.	Defective switch.	Disconnect level control and with ohmmeter perform a continuity check. Actuate switch manually. Closed switch should read zero resistance, open switch infinite resistance. If not, replace switch.
	Insufficient liquid level to actuate controls.	Allow liquid level to rise 3" to 4" above switch turn-on point.
Pump will not shut off.	Level controls tangled.	Free the level controls.
	Pump is air locked.	Shut off power for approximately 1 minute, then restart. Repeat several times to clear air from pump. If system includes a check valve, a 3/16" hole should be drilled in discharge pipe approximately 2" above discharge flange connection.
	Liquid inflow matches pump capacity.	Larger pump required.

<b>PROBLEM</b>	<b>PROBABLE CAUSES</b>	<b>CORRECTIVE ACTION</b>
Pump runs but does not discharge liquid.	Check valve installed backwards.	Check flow indicating arrow on check valve body to insure it is installed properly.
	Check valve stuck or plugged.	Remove check valve and inspect for proper operation.
	System head too high for pump.	Check pump performance curve.
	Inlet to impeller plugged.	Pull pump and clean.
	Pump is air locked.	(See corrective action above)
	Improper wiring.	Check wiring.
Pump does not deliver rated capacity.	System head too high for pump.	Check pump performance curve.
	Low voltage, speed too low.	Check for proper supply voltage to make certain it corresponds to nameplate voltage.
	Impeller or discharge pipe is clogged.	Pull pump and clean. Check pipe for scale or corrosion.
	Impeller may be rotating in the wrong direction.	Three phase units-interchange any two (2) power lead connections at pump side of control panel.
	Impeller wear due to abrasives or corrosion.	Replace worn impeller.
	Improper wiring.	Check wiring.
Pump Cycles continuously.	No check valve in long discharge pipe allowing liquid to drain back into basin.	Install check valve in discharge line.
	Check valve leaking.	Inspect check valve for correct operation.
	Liquid basin too small for inflow.	Install larger size liquid basin
	Level controls set too close together.	Lengthen distance between floats.



**Yeomans Pump – Div. Yeomans Chicago Corporation**

Shipping Address:

3905 Enterprise Court  
Aurora, IL 60504

Mailing Address:

P.O. Box 6620  
Aurora, IL 60598-0620

(630) 236-5500 PHONE  
(630) 236-5511 FAX

[www.yeomanspump.com](http://www.yeomanspump.com)