

Wolter Low Noise Silent Box

- SDX Series
- SD Series

Air in Motion.
Wolter Fans.

wolter 

Wolter Low Noise Silent Box - SDX, SD

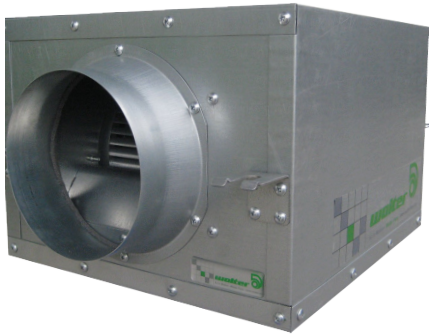

Design features

- › Casing made of galvanised sheet steel
- › Acrylonitrile-butadiene rubber acoustic insulation for SDX series (tested to BS 476: Part 6 & 7)
- › Low noise levels
- › Screwed panels allow easy access to the fan
- › Low & Compact height profile
- › Easily connected to standard tubes / ductwork

Casing

Fan casing made of galvanized sheet steel and SDX series insulated with sound absorbing acrylonitrile-butadiene rubber.

Motorized impeller

2 step motors for SDX/SD 100 ~ 200M & SDX/SD 200ML - This allows speed adjustment by means of a simple step switch. The forward-curved centrifugal impellers are made of galvanised sheet steel. The impeller is fixed directly onto the external rotor motor and the motorised impeller unit is dynamically balanced at two planes according to G 2.5 (DIN ISO 1940). The ball bearings are maintenance free.

Induction motors for SDX/SD 200L & SDX/SD

250M, 250LE - IEC motors of protection Class IP54, insulation class F & optional Class H for operating at higher ambient temperatures can be offered.

Performance curves

The performance curves of these fans have been established in a test chamber according to AMCA 210 and indicate the static pressure increase ΔP_{st} as a function of the volume flow

Sound level

The sound pressure dB(A) shown in table next page is measured at 1,5 meter from the fan casing with connected ducts on both inlet and outlet side.

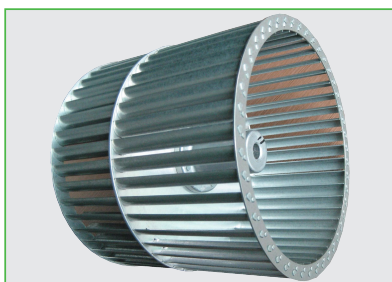

Technical Data

(Power Supply 50Hz 220V)

Model Size	Speed [1/min]	Power [W]	Current [A]	Capacitor [µf]	Volume Flow [m ³ /h]	Sound Pressure Level [dB(A)] 1,5m	Weight [KG]
SDX 100 / SD 100	1330	35	0,16	1	190	22 / 23	5,5
	1200	27	0,13		150	17 / 18	
SDX 100L / SD 100L	1350	40	0,18	1,2	330	24 / 25	5,8
	1260	36	0,16		280	20 / 21	
SDX 150 / SD 150	1350	40	0,18	1,2	360	26 / 27	6,5
	1260	36	0,16		290	22 / 23	
SDX 160 / SD 160	1290	75	0,35	2,5	520	30 / 31	8,4
	1200	70	0,33		420	27 / 28	
SDX 160L / SD 160L	1330	105	0,50	2,5	690	31 / 32	8,7
	1250	100	0,46		550	28 / 29	
SDX 200M / SD 200M	1330	105	0,50	2,5	820	32 / 33	9,8
	1250	100	0,46		650	29 / 30	
SDX 200ML / SD 200ML	1330	105	0,50	2,5	940	33 / 34	10,5
	1250	100	0,46		710	30 / 31	
SDX 200L-4 / SD 200L-4	1400	250	1,73	12	1400	43 / 44	14
SDX 250M-4 / SD 250M-4	1350	550	3,94	25	2160	50 / 52	20
SDX 250M-4K / SD 250M-4K	1380	370	2,47	16	1630	49 / 51	18
SD 250LE-4	1380	370	2,47	16	1680	46	16
SD 250LE-4K	1400	250	1,73	12	1250	45	15

Note: 1, The volume flow indicated above is measured in chamber at 0 static pressure;

2, The sound level are measured at the 1.5 meter from the fan body when ducts are connected on both inlet and outlet side.

3, Subject to change without prior notice.

Dimension

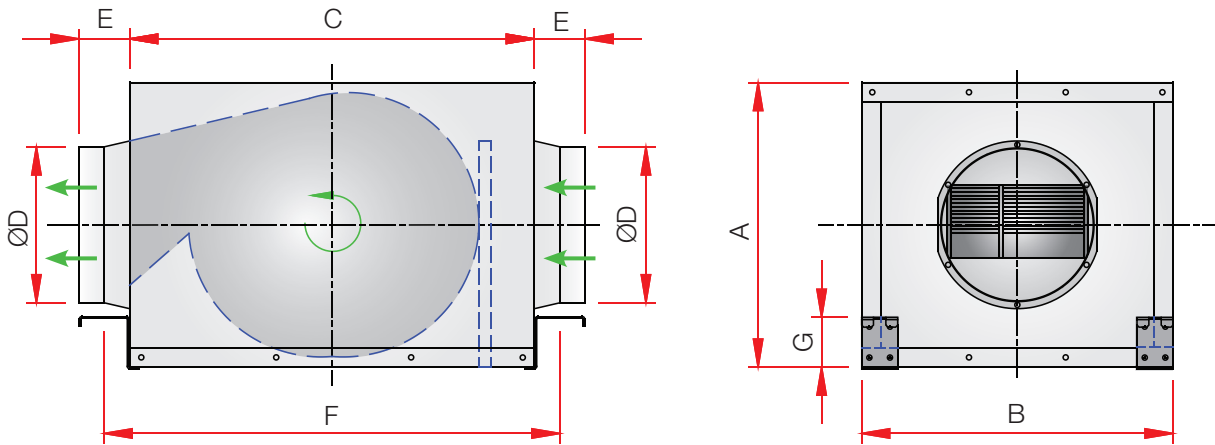

Model	A	B	C	D	E	F	G
SDX 100 / SD 100	183	291	292	99	52	336	51
SDX 100L / SD 100L	183	291	292	149	61	336	51
SDX 150 / SD 150	205	291	302	149	61	345	51
SDX 160 / SD 160	231	317	339	159	61	383	51
SDX 160L / SD 160L	231	317	339	199	72	383	51
SDX 200M / SD 200M	252	378	399	199	72	442	51
*SDX 200ML / SD 200ML	252	378	399	199	72	442	51
SDX 200L / SD 200L	300	530	470	199	72	513	51
SDX 250M / SD 250M	335	570	505	249	90	548	51

Note: 1, All dimensions in mm;

2, * 200ML does not come with inlet nozzle.

3, We reserve the right to alter measurements without notice in case of technical improvements.

Dimension

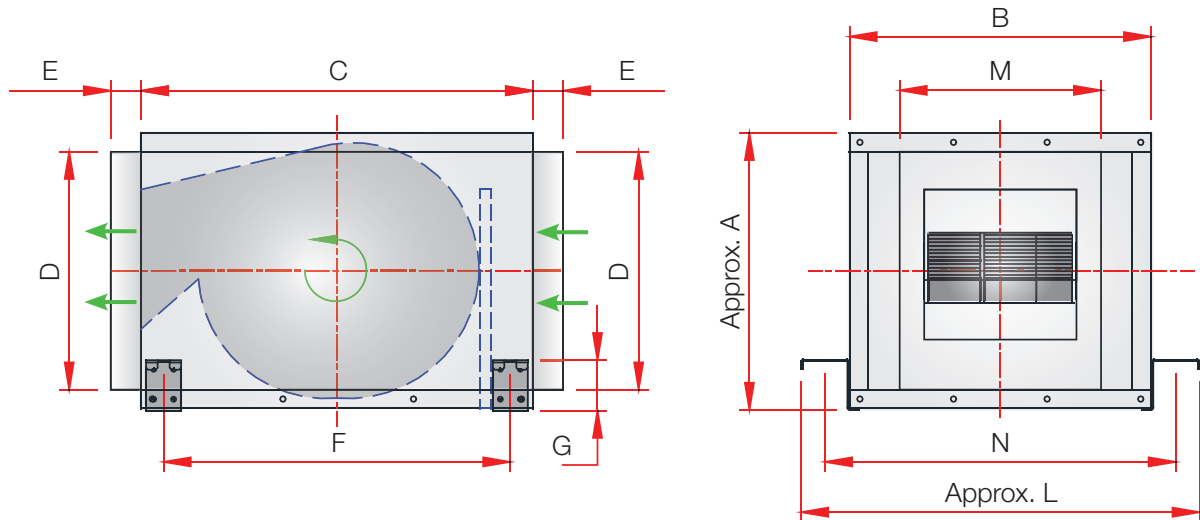

Model	A	B	C	D	E	F	G	L	M	N
SD 250LE	335	400	429	290	40	380	51	500	270	460

Note: 1, All dimensions in mm;
 2, We reserve the right to alter measurements without notice in case of technical improvements.



For SDX 100 to SDX 200M and 200ML

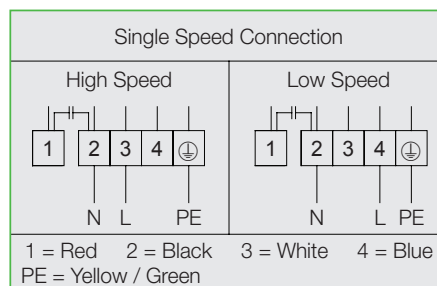

For SDX 200L, 250M, 250LE

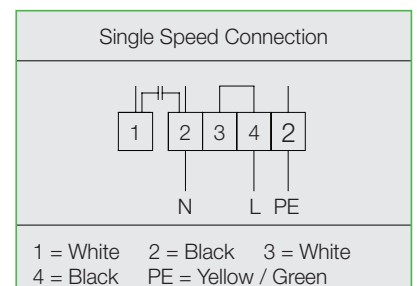

Performance curves

SDX 100 / SD 100

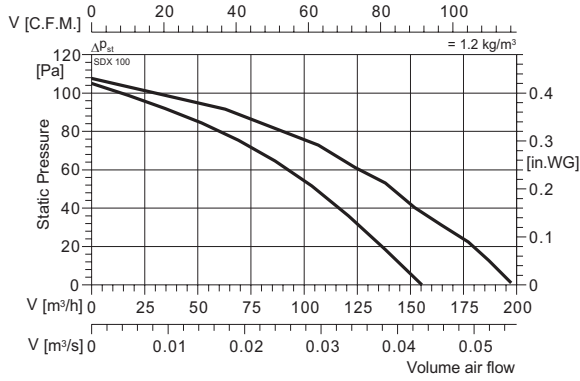

SDX 100L / SDX 100L

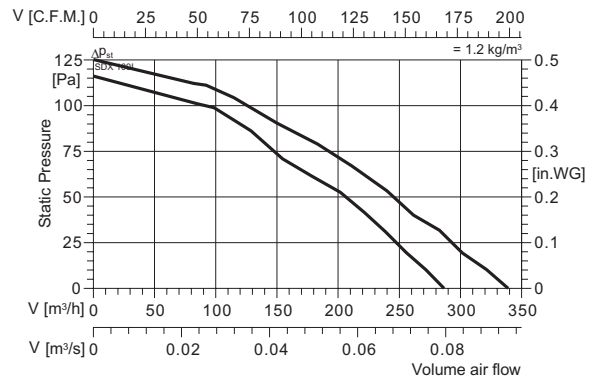

SDX 150 / SD 150

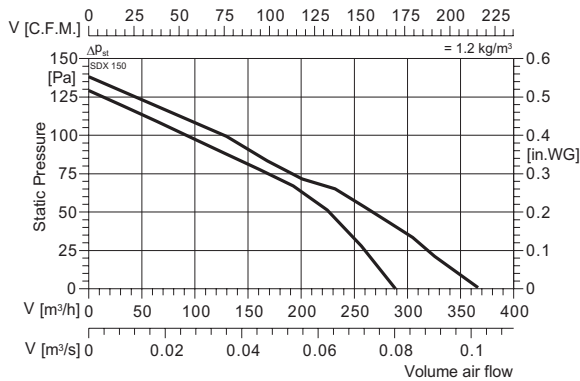

SDX 160 / SD 160

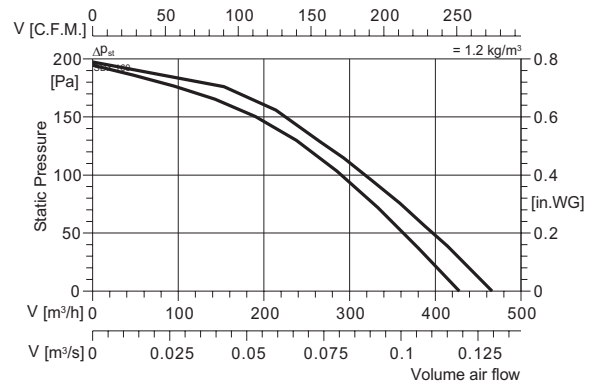

SDX 160L / SD 160L

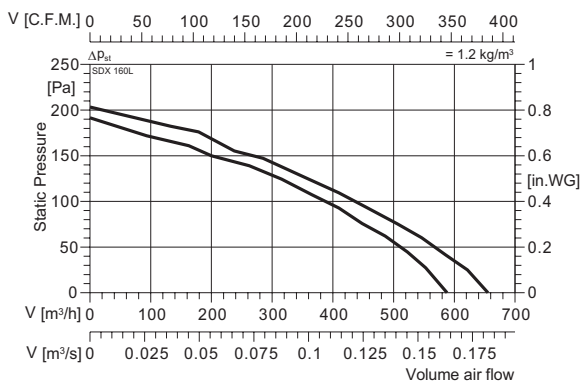

SDX 200M / SD 200M

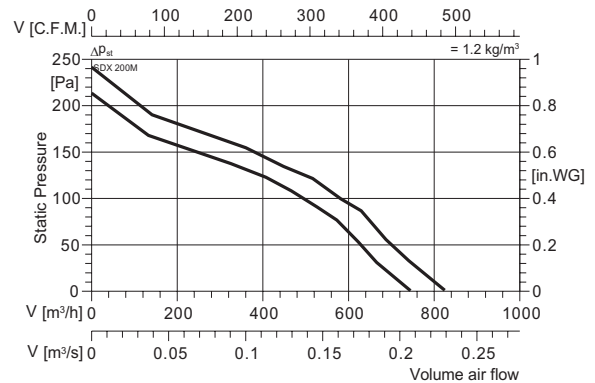

SDX 200ML / SD 200ML

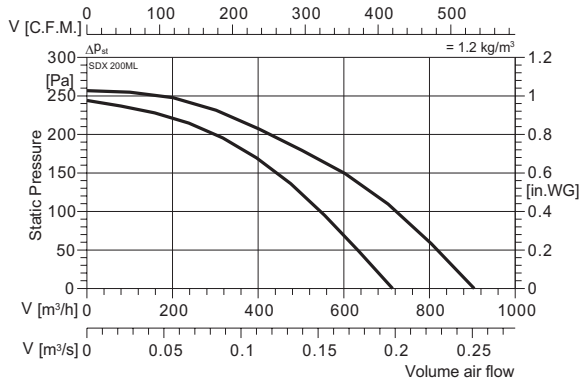

Performance curves

SDX 200L-4 / SD 200L-4

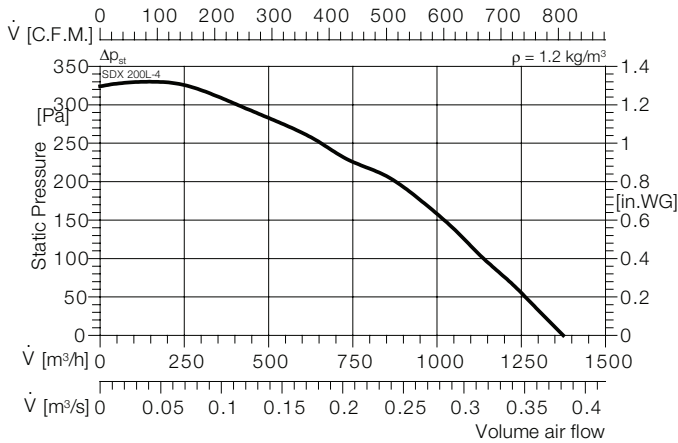

SDX 250M-4 / SD 250M-4

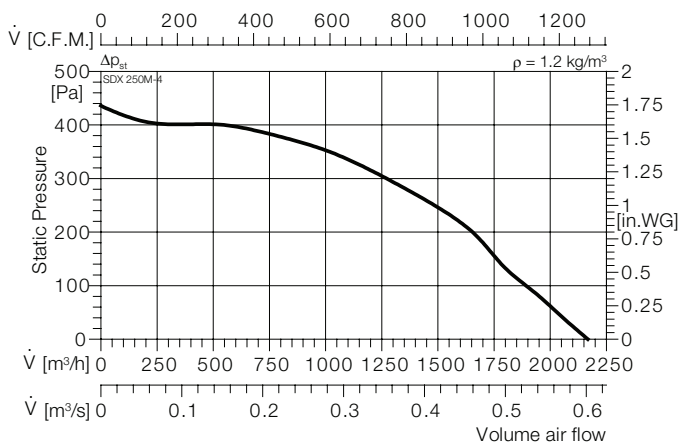

SDX 250M-4K / SD 250M-4K

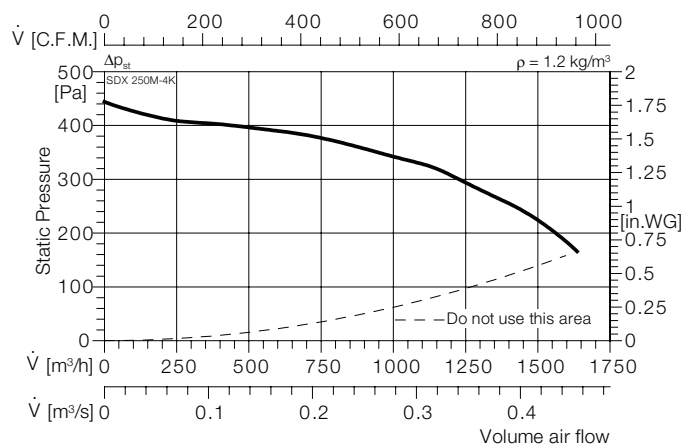

SD 250LE-4

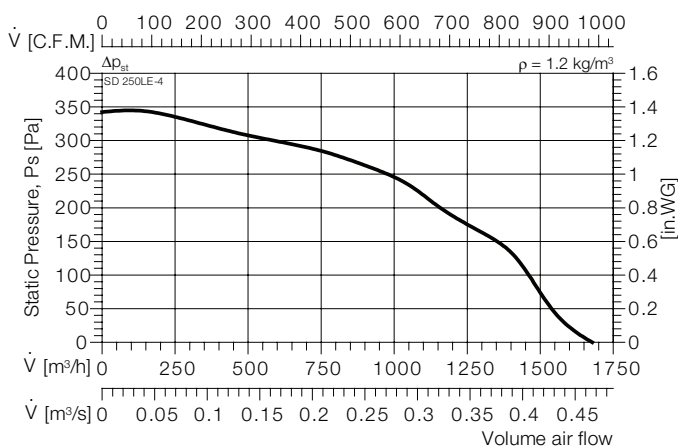

SD 250LE-4K

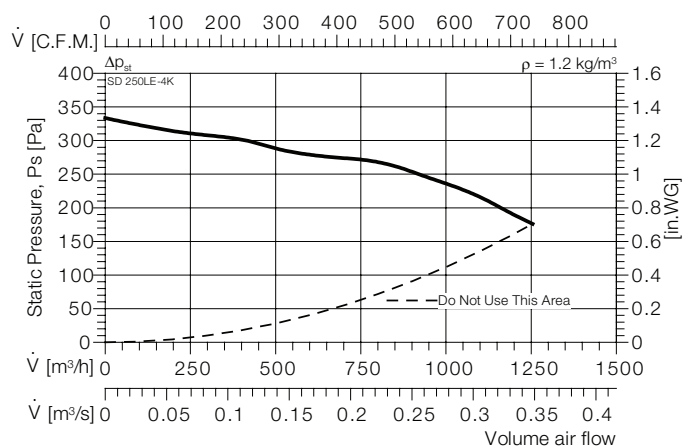

Wolter Sales Network

Inland

Ing. Günther Rößler
D-07619 Schkölen
Tel. (+49) 03 66 94 / 22 359
Fax (+49) 03 66 94 / 22 357
guenther.roessler@wolterfans.de

Mattias Industrievertretungen
D-16259 Bad Freienwalde
Tel. (+49)03344/301994
Fax (+49)03344/301996
thomas.mattias@wolterfans.de

Industrieservice Drexler
D-49080 Osnabrück
Tel. (+49) 0 541 / 20 04 88 3
Fax (+49) 0 541 / 20 04 88 4
wolfgang.drexler@wolterfans.de

Burkhardt Projekt GmbH
D-67583 Guntersblum
Tel. (+49) 0 62 49 / 82 01
Fax (+49) 0 62 49 / 88 58
info@bp-wolter.de

Friedrich Glock
D-97980 Bad Mergentheim
Tel. (+49) 0 79 31 / 37 44
Fax (+49) 0 79 31 / 28 58
friedrich.glock@wolterfans.de

Europe

Danmark:

Air-Con Danmark A/S
DK-8400 Ebeltoft
Tel. (+45)086/345111
Fax (+45)086/345810
jbj@air-con.dk

Hungary:

Air-Technik Légtechnikai Kft.
HU-2040 Budaörs
Tel. (+36)023/428533
Fax (+36)023/428544
bp.air-technik@troges.hu

Ireland:

Finheat Ltd.
IE-Dublin 12, Walkinstown
Tel. (+353)01/4564066
Fax (+353)01/4564071
sales@finheat.com

Lithuania:

JSC Saldos Prekyba
LT-78109 Siauliai
Tel. (+37)041/540212
Fax (+37)041/596176
prekyba@saldita.lt

Netherlands:

AirFan B. V.
NL-7442 CX Nijverdal
Tel. (+31)054/8366366
Fax (+31)054/8365320
ventilatie@airfan.nl

Rucon B. V. Ventilatoren
NL-3840 AG Harderwijk
Tel. (+31)034/1411670
Fax (+31)034/1411690
verkoop@rucon.nl

Österreich:

Wolter Werksvertretung Österreich
A-4040 Linz
Tel. (+43) 07 32 / 75 77 07
Fax (+43)07 32 / 75 77 07 75
wolter.linz@aon.at

Wolter GmbH Maschinen-und Apparatebau KG

Am Wasen 11
D-76316 Malsch / Germany
Tel. +49 (0) 7204/9201-0
Fax +49 (0) 7204/9201-11
www.wolter.eu
info@wolter.eu

Poland:

Wentoprodukt
44-100 Gliwice
Tel. (+48)32 331-34-24
Fax (+48)32 729-76-53
biuro@wentoprodukt.pl

Portugal:

Safe Park Ventilação Industrial Lda.
P-2675-240 Odiveelas
Tel. (+351) 21 93 / 75 265
Fax (+351) 21 93 / 86 061
safepark@netcabo.pt

Russia:

Euroclimat-Prof
RU-107082 Moskau
Tel. (+7) 4 95 / 97 57 530
Fax (+7) 4 95 / 97 57 530
gso@euroclimat.ru

Schweiz:

Anson AG Zürich
CH-8055 Zürich
Tel. (+41) 0 44 / 46 11 111
Fax (+41) 0 44 / 46 13 111
info@anson.ch

Ventra Technik AG
CH-8599 Salmsach
Tel. (+41) 0 71 / 46 11 447
Fax (+41) 0 71 / 46 11 448
ventra@bluewin.ch

Turkey:

Air Trade Centre Ltd Sti Türkiye,
TR-34418 Seyrantepe / Istanbul
Tel. (+90) 02 12 / 28 34 510
Fax (+90) 02 12 / 27 83 964
atc.turkey@airtradecentre.com

United Kingdom:

Wolter UK Ltd.
GB-B37 7UQ Solihull
Tel. (+44) 01 21 / 63 55 390
Fax (+44) 01 21 / 63 55 391
info@wolteruk.com

Middle East and North Africa

Egypt:

Tiba Engineering Industries Co.
Nasr City, Cairo
Tel. (+2) 02 / 40 22 866
Fax (+2) 02 / 40 44 771
tibaengineering@manz-group.com

Israel:

Lea Ventilation Industries Ltd.
IL-27113 Kiriyat-Bialik, Israel
Tel. (+972) 0 48 / 76 23 57
Fax (+972) 0 48 / 76 20 51
mail@lea.co.il

United Arab Emirates, Kuwait, Lebanon:

Wolter Ventilation LLC
Energy International
P.O. Box 3562 Sharjah, UAE
Tel. (+971) 06 / 53 43 477
Fax (+971) 06 / 53 43 756
energys@emirates.net.ae

Asia

China Mainland:

Taizhou Wolter Ventilation Co. Ltd.
Hengjie, Luqiao District
Taizhou City, Zhejiang
Tel. (+86) 576 / 26 22 666 (26 52 888)
Fax (+86) 576 / 26 56 830

Hongkong:

Wolter Asia Ltd.
Hong Kong
Tel. (+852) 0 24 / 56 01 98
Fax (+852) 0 24 / 56 02 90
info@wolter.com.hk

India:

Wolter Ventilators India Pvt. Ltd.
867 D, Block-A, Sushant Lok, Phase-I,
Gurgaon - 122009 (Haryana)
Tel. +91 124 2577797, 4261001-3
sales@wolterindia.in

Indonesia:

PT. Agung Kipas Kastara.
ID-14440 Jakarta Indonesia
Tel. +62 (0) 21 / 6667 6925, 6667 6926
Fax +62 (0) 21 / 6667 6927
indowolter@cbn.net.id

Korea:

Kaceco-Wolter
14-1, Dang-dong, Gunpo-shi, Gyeonggi-do
Tel. +82 (0) 31 / 4773 104
Fax +82 (0) 31 / 4773 132
wolter@kaceco.com / info@kaceco.com

Malaysia:

Vibrantech (M) Sdn Bhd.
47200 Petaling Jaya Selangor, Malaysia
Tel. +603 (0) 7847 3500
Fax +603 (0) 7847 3380
sales@vibrantech-sb.com

Singapore:

Wolter Pte. Ltd.
SG-569738 Singapore
Tel. (+65) 0 63 / 52 95 48
Fax (+65) 0 63 / 52 95 47
info@wolterfans.com.sg

Sri Lanka:

Sirocco Air Technologies (Pvt) Ltd.
28/12, Gemunu Mawatha, Kotuwegoda,
Rajagiriya, Sri Lanka
Tel. +94 11 7 392 010
Fax +94 11 7 392 015
suren@sairt.com

Taiwan:

Waxlink International Co., Ltd.
8F No. 218 Roosevelt Rd., Sec. 6
Taipei, Taiwan
Tel. (+886) 02 / 89 32 11 96
Fax (+886) 02 / 89 32 11 97
waxlink.tech@msa.hinet.net

Thailand:

Wolter Ventilation Co., Ltd.
Thamai Kratumban Samutsakorn 74110
Thailand
Tel. +66 (0) 3486 6555
Fax +66 (0) 3486 6599
natiphan@wolterfan.com

Australia

The Sydney Fan Company.
NSW 2147, Sydney, Australia
Tel. +61 (0) 2 / 9624 4000
Fax +61 (0) 2 / 9624 4100
sales@thesydneyfancompany.com

