

Products and Components



You've got the application, we've got the solution

Within the Business Unit Pumps & Systems, Food & Pharmaceutical holds a crucial position all over the world with regard to uncompromising hygiene and most demanding process requirements in all manufacturing areas.

Business Field Food & Pharmaceutical

- Beverages
- Breweries
- Wine
- Biotechnology
- Cosmetics
- Pharmaceuticals
- Fish
- Fruits
- Starch
- Sugar
- And similar

We are where you are

With worldwide more than 1,900 employees at five development and production sites as well as 30 sales offices, a cooperation partner and another 200 NETZSCH representatives we are close to you wherever you are.

Product range

NEMO® Progressing Cavity Pumps

Hygienic pumps
Hygienic mini pumps
Aseptic pumps

NETZSCH Accessories

Protection devices
Flushing/sealing pressure devices
Control systems
Trolley assemblies
Tools

TORNADO® T2 Rotary Lobe Pumps

Hygienic rotary lobe pumps
T.Sano®

NETZSCH Barrel Emptying System

For emptying standard containers
from 20 l to 200 l
Flow rates approximately
6 ml - 10 m³/h Clean drain,
Remaining amount without
liner <1%

We have our finger on the pulse

Products should keep fresh for a longer period of time but still maintain their original quality standard. Our pumps as the „driving force“ in your production process are a key ingredient of your product quality. We develop, manufacture and sell positive displacement pumps which ensure in all process stages a hygienic and smooth conveyance of high quality and shear-sensitive fluids.

Driving forces

Two different types of pumps are available for various process requirements: NEMO® hygienic and aseptic progressing cavity pumps and NETZSCH TORNADO® hygienic rotary lobe pumps. For each application your pump is individually laid out for you.

Engineering partnerships

With our customers from all over the world we are able to incorporate the latest market trends and requirements into the development and improvement of our products. Therefore new possibilities for your manufacturing process continually arise.

NEMO® Hygienic and Aseptic Progressing Cavity Pumps

Characteristics and typical components

The hygienic design of components and machinery as well as the cleanability of process plants are defined in a multitude of rules and regulations.

NEMO® pumps are constructed, manufactured and tested according to EHEDG regulations (European Hygienic Equipment Design Group) or QHD regulations (Qualified Hygienic Design). The materials used are certified in accordance with FDA (Food and Drug Administration) and EU-VO 1935/2004.

Additionally, NEMO® hygienic and aseptic progressing cavity pumps are certified according to the 3-A Sanitary Standards of the US and GOST-R (Russian Certificate of Conformity).

Large range of capacities and pressures

- Flow rates from a few ml/h up to 140 m³/h
- Pressures up to 24 bar

Wide range of applications

NEMO® hygienic and aseptic progressing cavity pumps are normally used for fluids having the following properties:

- Shear-sensitive
- Of low up to high viscosity
- Smearing and non-smearing
- With or without solids
- Dilatant or thixotropic
- Abrasive
- Adhesive

Tempered hygienic pump

The tempered hygienic pump is particularly suitable for media which must be tempered consistently during the conveying process.

Advantages

- Smooth conveyance
- Long process cycles due to contamination proof design
- Almost pulsation-free conveyance
- Flow rate in proportion to speed with high dosing accuracy over a wide speed range
- Flow rate independent of variances in pressure or viscosity
- Product intake possible in vacuum conditions up to almost total vacuum
- The housing is designed with no dead space to improve flow and avoid settling of solids
- All contact surfaces in polished version to avoid caking of the fluid and to facilitate cleaning
- For lubricating fluids, open, patented, hygienic joints
- Version with flexible rod for uncompromising hygiene and long serviceable life
- Elastomers in food standards according to FDA and EU-VO 1935/2004
- Horizontal or vertical installation
- Service friendly

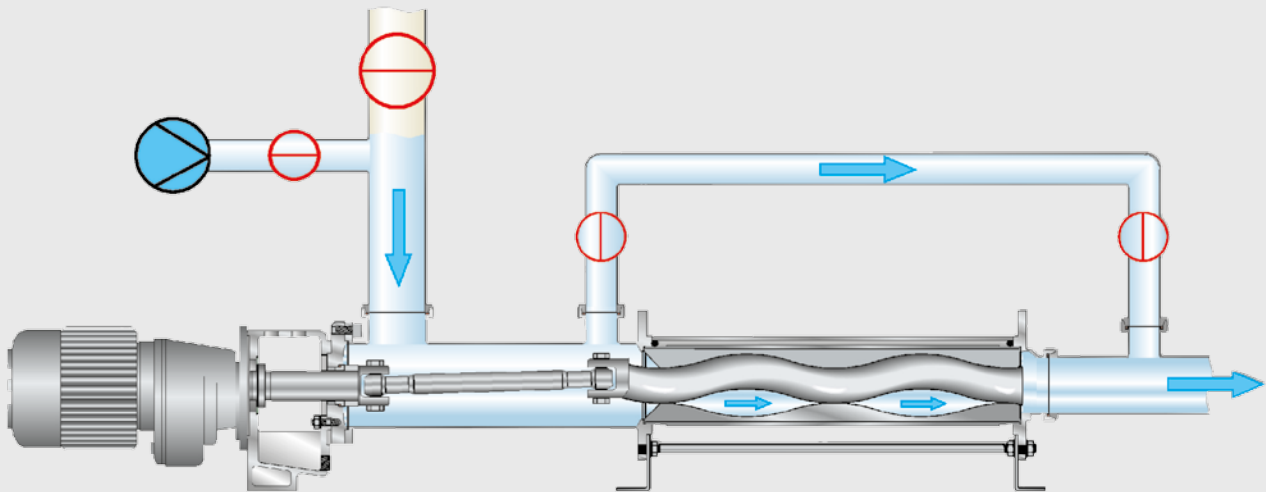





CIP/SIP Process

For the CIP process, the entire system requires a cleaning fluid velocity of at least 1.5 m/s and to facilitate this the NEMO® hygienic and aseptic progressing cavity pumps are equipped with additional cleaning ports. The position of these ports can be determined to suit the application and they require a bypass pipe.

The bypass is also required for the SIP process. In both the CIP and SIP processes the NEMO® pumps are operated intermittently.

Tangential cleaning ports guarantee complete emptying of the NEMO® pump. All pump materials used are suitable for CIP and SIP processes.

-  CIP pump
-  CIP medium
-  valve open
-  valve closed

NEMO® Hygienic Pump in Block Construction and Bearing Housing Design

NEMO® BH Hygienic pump in standard version

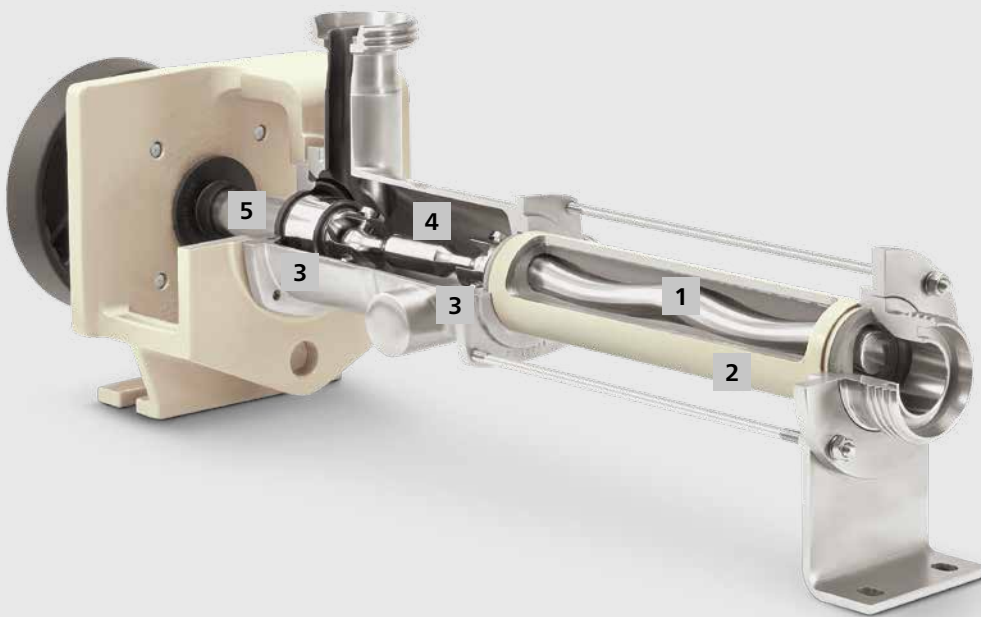

1 Rotor

Made of stainless steel.

2 Stator with reduced wall thickness

For changing product temperatures a patented stator with reduced elastomer wall thickness is used. In addition, a thermal stator protector (STP-2 or STP-D) for overheating and dry running protection is available.

3 Hygienic joints

Patented, open, with no dead space, hygienic joints for optimal cleaning.

4 Drive chain

Drive and connection shaft with coupling rod and two hygienic joints for drive transmission to the rotor.

5 Sealing housing

Various shaft sealings are available.



Hygienic joint

The specially developed joints are continuously lubricated by the medium without the risk of medium being caught in any dead space.

Characteristics and typical components

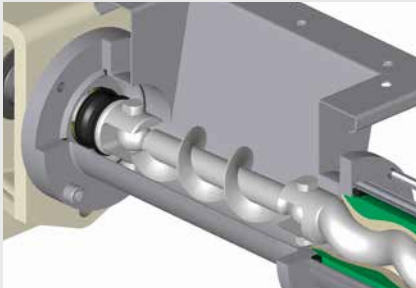

Feeding screw hopper

For highly viscous and pasty products, the pump is optionally equipped with a feeding screw and a hopper to allow for an optimal filling of the conveying chambers.

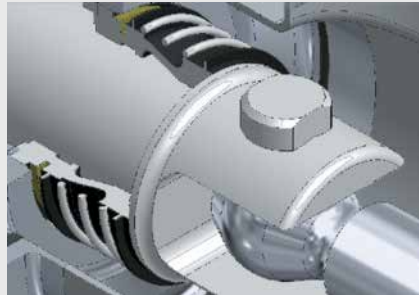

Mechanical seal with elastomer bellows (standard)

Single seal, unbalanced, independent of direction of rotation, elastomere bellows with or without knife edge. Seals in SIC. On request elastomere in compliance with FDA standards.

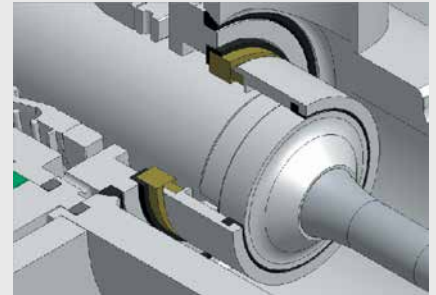

Mechanical seal with spring (optional)

Single seal, balanced, independent of direction of rotation, with product protected spring. Smooth surface. Seals in SIC. Elastomere in compliance with FDA standards.

NEMO® BH tempered hygienic pump



- Full heating jacket
- Tri-Clamp connection of gear and housing for the rapid decomposition
- End fittings are easy to remove

NEMO® Aseptic Pump with Bearing Housing

NEMO® Aseptic Pump

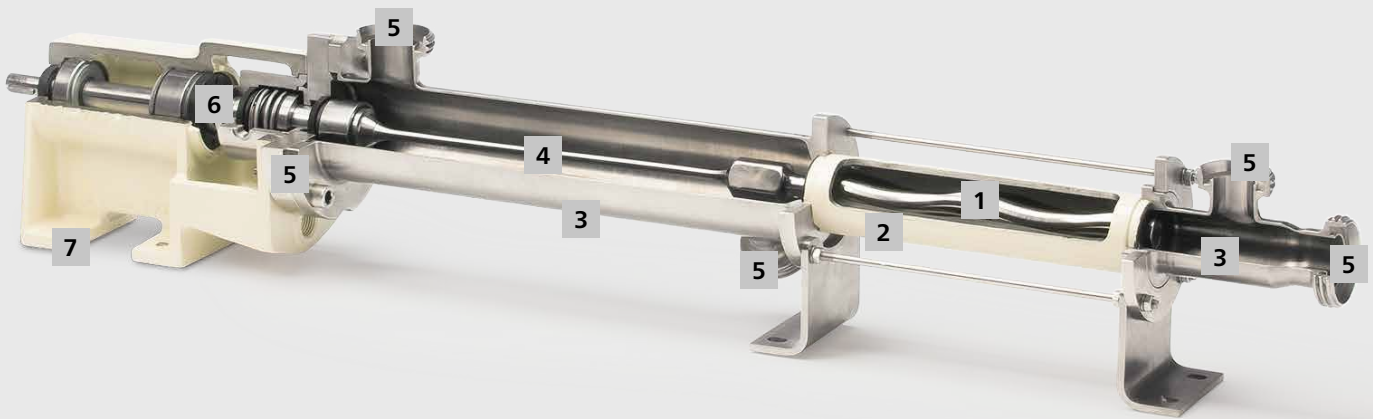

1 Rotor

Made of stainless steel.

2 Stator with reduced wall thickness

For changing product temperatures a patented stator with reduced elastomer wall thickness is used. In addition, a thermal stator protector (STP-2 or STP-D) for overheating and dry running protection is available.

3 Housing/discharge flange

The pump housing has a reduced diameter for optimal flow velocity

and minimized pump volume. The body flange is located directly above the shaft seal avoiding any dead space. Therefore the deposit of fluid in the housing during the manufacturing cycle is eliminated.

4 Flexible rod

5 Double buffered static seals

All static seals to the atmosphere are double sealed chambers. Sterile condensate, vapour and/or detector fluid is continuously supplied to the chambers. Through the contaminationproof design the process cycle can be reduced by the removal of some

sterilization processes. Consequently output capacity increases as the number of cleaning cycles decreases.

6 Sealing housing

Double mechanical seal in tandem arrangement with unpressurized, static or dynamic quench.

7 Bearing housing

Widely spaced, heavy duty bearings ensure optimum concentricity of the drive shaft and are able to withstand large axial loads. The free shaft end allows for the use of all types of drive.

Characteristics and typical components



Flexible rod

The flexible rod for universal use in the NEMO® Hygienic Plus series is corrosion-proof, with no dead space, wear and maintenance free because there are no components moving against each other as in other joint types. Neither lubrication nor seals are required so that the lubricity of the fluid does not have to be taken into consideration. Ideal for pumping highly sensitive products with or without solids and for uncompromising hygienic applications. Also available as a 3-A flexible rod.

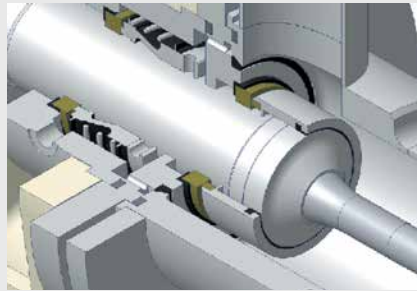

Double mechanical seal in tandem arrangement

Double mechanical seal in tandem arrangement with unpressurized, static or dynamic quench. Mechanical seals in SIC. Elastomer in compliance with FDA standards. The design of the rotating unit guarantees the seal integrity at changing temperatures and pressures. The seal complies with EHEDG and QHD regulations.

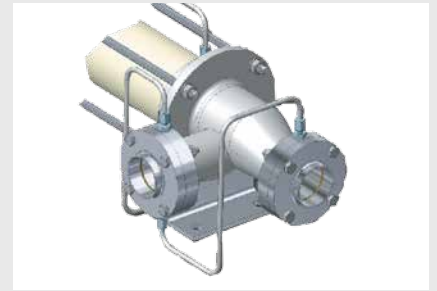

Pipework (optional)

The pipework circulates sterile condensate, vapour and/or detector fluid to the double acting, closed seal lines.

NETZSCH TORNADO® Hygienic Rotary Lobe Pump

Hygienic Rotary Lobe Pump T.Sano®

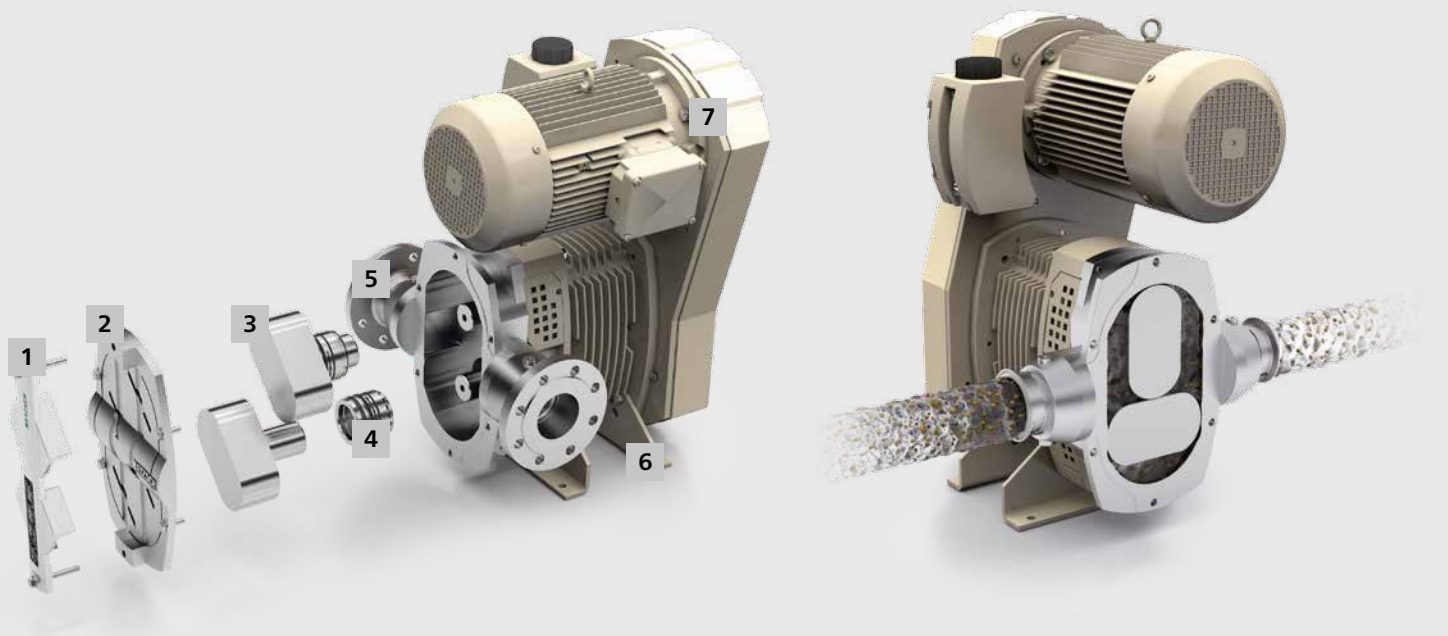

1 Rotor setting device

Using the setting device, the lobes are adjusted radially and axially.

2 Front cover

As an option, the pump cover can be heated.

3 Rotor

The stainless steel lobes are fixed externally. The surface of the lobes is perfectly smooth, and prevents any dead space.

4 Seal

The cartridge design is available in single and double acting versions. The seal is positioned specifically to avoid dead space, and the rotating seal faces are within the conveyed medium.

5 Rotor case

The suction housing is available with two options for connections: flanged or threaded. The interior of the housing has no dead space.

6 Bearing housing

The bearing housing is designed according to the BSS System i.e. the bearing housing is separate from the pump housing. The ball bearings are lubricated for life.

7 Tooth belt drive

Synchronisation and drive via maintenance free tooth belt drive, which runs completely oil free.

Characteristics and typical components

The hygienic design of components and machinery as well as the self-draining cleanability of parts of a plant are defined in a multitude of rules and regulations.

CIP-/SIP-Process

For the CIP process, in the whole system the cleaning fluid should have a flow velocity of at least 1.5 m/s, thus, NETZSCH TORNADO® hygienic rotary lobe pumps may also be used as cleaning pumps, i.e. delivery and cleaning with the same pump. All materials are in line with CIP and SIP processes.

Large range of capacities and pressures

- Flow rates up to 120 m³/h
- Pressures up to 10 bar
- In 6 different sizes

Wide range of applications

NETZSCH TORNADO® hygienic rotary lobe pumps are normally used for fluids having the following properties:

- Shear sensitive
- With or without solids
- Medium up to high viscosity (300 mPas to 100.000 mPas)
- Thixotropic and dilatant
- Lubricating and non lubricating
- Adhesive

Advantages

- Compact design, high performance
- Suitable for a wide temperature range
- No dead space
- CIP and SIP capable
- Gentle product handling
- Reversible flow direction
- Flow rate in proportion to speed
- Reversible operation
- Vibration free, low noise emission
- Easy maintenance of the conveying elements and shaft seal without having to remove the pump from the pipe line