

NETZSCH

Proven Excellence.



NETZSCH Pumps compliant to API 676 3rd edition

Individual Solutions for Mid- and Downstream

Pumps & Systems

NETZSCH API Compliant Pumps 676 3rd Edition

The highest standards for equipment and safety are a basic requirement for oil field work to ensure that processes remain safe and reliable.

NETZSCH offers pump systems consisting of a pump, drive, base plate and various accessories, which are meeting the requirements of API 676 3rd edition, NACE MR0175, MR0103, NORSOK and many more. The sophisticated and reliable design meets the particular pump job requirements and contributes to efficient process control.

These systems are available with NEMO[®] Progressing Cavity Pumps, TORNADO[®] Rotary Lobe Pumps as well as NOTOS[®] Multi Screw Pumps. They contribute to improved safety and reliability due to their robust construction and intelligent system integration.

Fluid Properties, pumped by NEMO[®] and TORNADO[®]

- Shear-sensitive
- Low to high viscosity
- With or without solids
- Dilatant or thixotropic
- Low to highly abrasive
- Adhesive
- Multiphase liquids

Fluid Properties, pumped by NOTOS[®]

- Shear-sensitive
- Lubricating and non lubricating
- Low to high viscosity
- With low solid content
- Dilatant or thixotropic
- Low to medium abrasive
- Adhesive

We face unique challenges with our pump solutions

Wide Range of Applications

Enhanced oil recovery

- Water injection pumps
- EOR polymer transfer
- Surfactant transfer

Produced water management

- Produced water transfer and boosting
- Skimmed oil transfer

Well services

- Well Testing: Crude Oil Transfer
- Drilling mud: Decanter centrifuge feeding

Oil & Gas processing

- Open & closed drains transfer
- Flare KO drum pumps
- Crude oil transfer
- Hydrocarbon condensate transfer
- Rich MEG/Glycol
- Hydrocarbon sludge
- Multiphase transfer
- Pipeline reinjection
- Pipeline booster pumps

Refinery

- Asphalt, bitumen, tower bottoms
- Fuel oils
- Kerosine, diesel
- Catalyst slurry
- Lubricant oil
- Oily water treatment
- Sludge transfer

Storage & Distribution

- Crude oil transfer
- Tank stripping
- Oily sludge
- Loading/Unloading



Our Multi Screw Pump Family

The NOTOS® multi screw pump family comprises three series in multiple arrangements which serve a wide range of industries and applications. The superior quality standard meets the highest level of requirements from our customers.

2 NS – Two Screw Pump

- Flow up to 500 m³/h (2200 gpm)
- Pressure up to 16 bar (230 PSI)
- Temperature up to 300 °C (570 °F)
- Viscosity up to 100.000 cSt
- From non to light abrasive
- Corrosive
- Low to medium viscosities
- Lubricant Fluids



3 NS – Three Screw Pump

- Flow up to 350 m³/h (1500 gpm)
- Pressures up to 80 bar (1160 PSI)
- Temperature up to 300 °C (570 °F)
- Viscosity up to 15.000 cSt
- Non abrasive
- Non corrosive
- Low to medium viscosities
- Lubricant fluids



4 NS – Geared Twin Screw Pump

- Flow up to 1.500 m³/h (6600 gpm)
- Pressures up to 80 bar (1160 PSI)
- Temperature up to 300 °C (570 °C)
- Viscosity up to 200.000 cSt
- From non to medium abrasive
- Corrosive
- Low to high viscosities
- Non lubricant and lubricant fluids



NOTOS® in API-Compliant Design

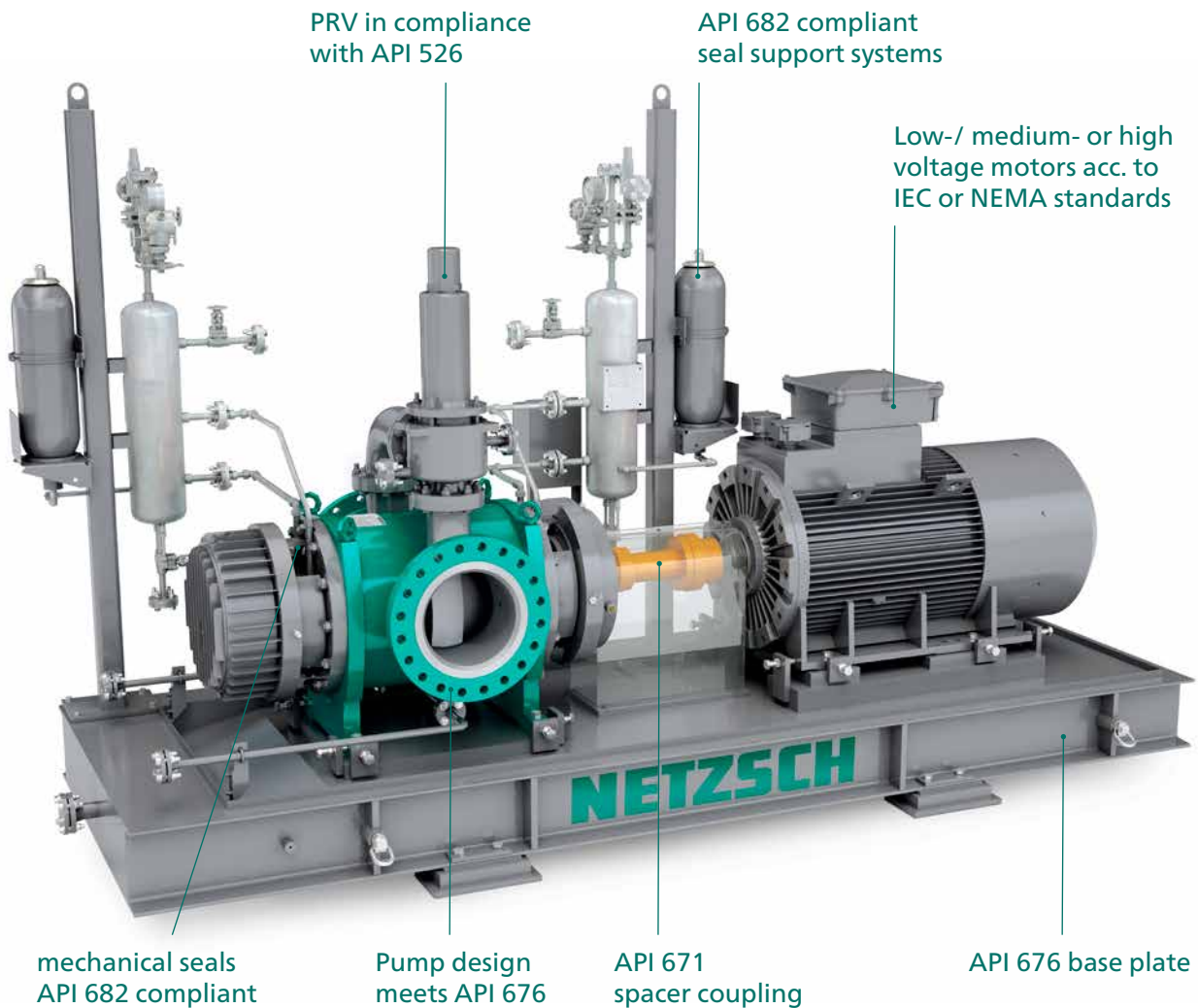

Pump Data

- Pump type: 4NS – Geared Twin Screw Pump
- Capacity: up to 1500 m³/h
- Pressure: up to 80 bar
- Medium: Asphalt, bitumen, crude oil, diesel, polymer, produced water with or without traces of solids
- Medium temperature: up to 300 °C
- Ambient temperature: - 45 °C to + 58 °C

Customer Benefits

- High performance with small footprint
- HEUD highest efficiency due to optimized screw profile
- One-piece screw design for maximum stiffness
- Customized design to fit individual needs
- Able to handle a wide range of temperatures and viscosities

Safety Accessories

- Seal support system
- Pressure relief valve
- Leakage, temperature and vibration sensors
- Noise enclosure

API Compliant Pump: TORNADO®

Pump Data

- Pump type: TORNADO® T.Proc Rotary Lobe Pump
- Capacity: up to 1000 m³/h
- Pressure: up to 10 bar
- Medium: Oil, oily water, produced water, slurries and mixtures with gas
- Medium temperature: up to 150 °C
- Ambient temperature: - 45 °C to + 58 °C

Customer Benefits

- Maximum wear resistance
- Available as rubber/metal and metal/metal type to fit individual needs
- FSIP Full Service In Place. Can be serviced in the oilfield.
- Oil free design

Safety Accessories

- Dry running protection
- Pressure relief valves
- Seal systems
- API base plate

API Seal System:
We offer all relevant API seal plans

Component mechanical seal or cartridge type:
Compliant to API 682

API Baseplate

Pump head:
Easy to access for maintenance

Maintenance free:
Robust drive and timing belt

Motor acc. to IEC or NEMA standard

By-pass with pressure relief valve

Life time lubricated bearing housing, oil free

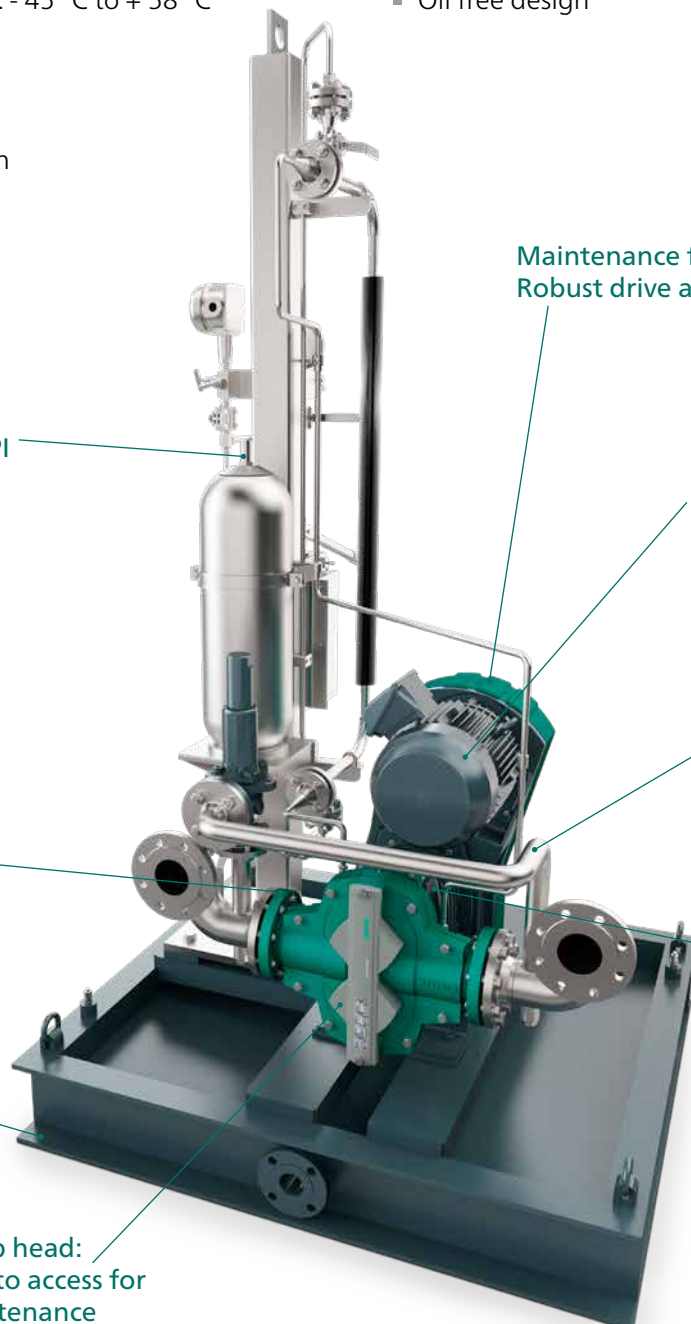

API Compliant Pump: NEMO®

Pump Data

- Pump type: NEMO® Progressing Cavity Pump
- Capacity: up to 110 m³/h
- Maximum allowable working pressure (MAWP): up to 48bar
- Medium: Produced water, slurries, polymer, MEG, crude oil with or without solids
- Casing design pressure: 50 bar
- Special feature: NORSOK/NACE MR0175/MR0103 on request

Customer Benefits

- All pressurized parts cast – no welding documentation
- Less documentation, inspections and less risk in manufacturing
- More robust – 2xAPI676 nozzle loads standard
- Reduced lead times

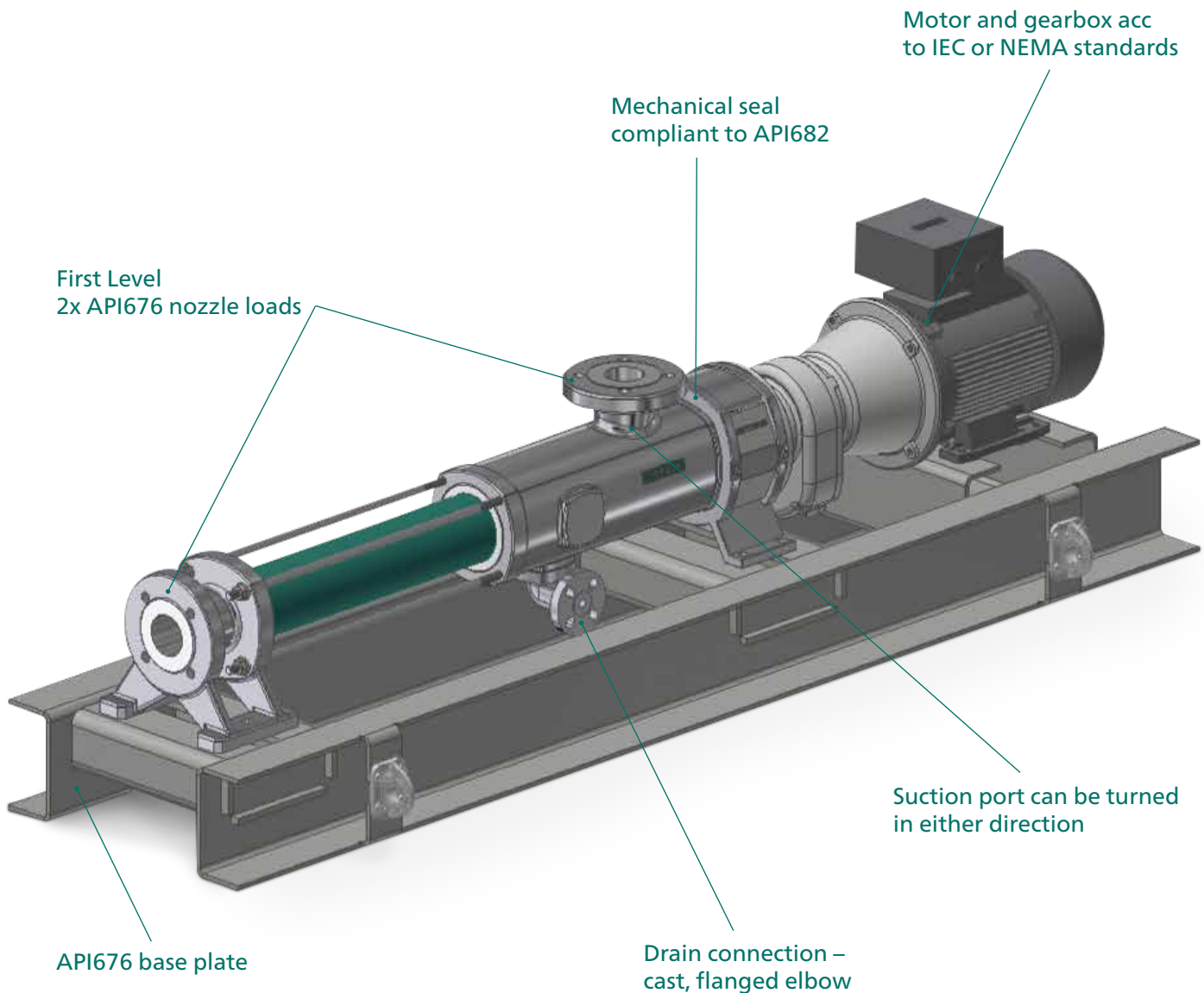

NETZSCH API Compliant Pump 676 3rd Edition

As an example of the fulfillment of the API requirements please see the NEMO® L.Cap® pump, detailed below: the biggest progressing cavity pump in the world.

Safety Accessories

- Pressure relief valves according API
- Pressure monitoring
- Overpressure protection
- and many more

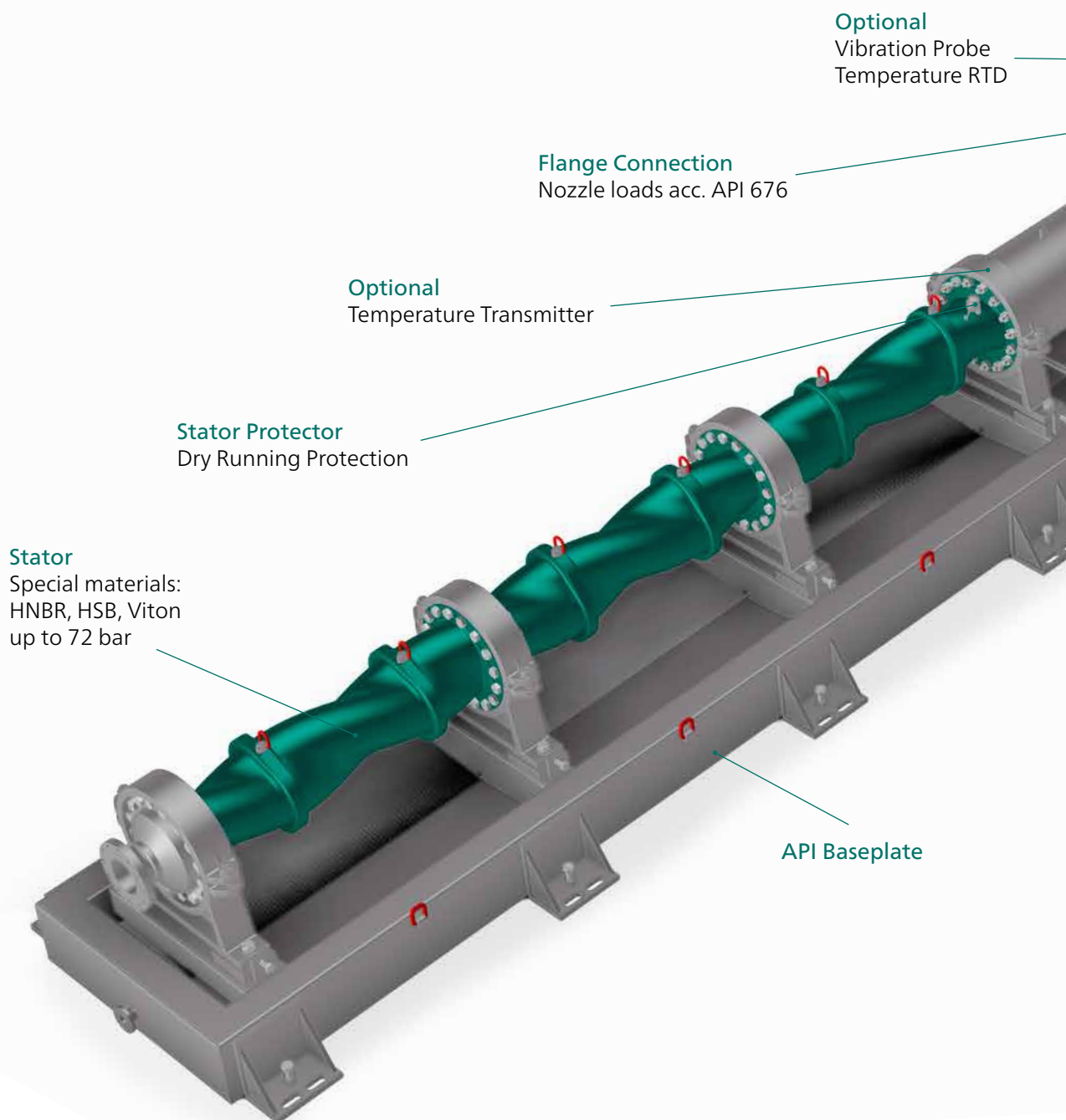

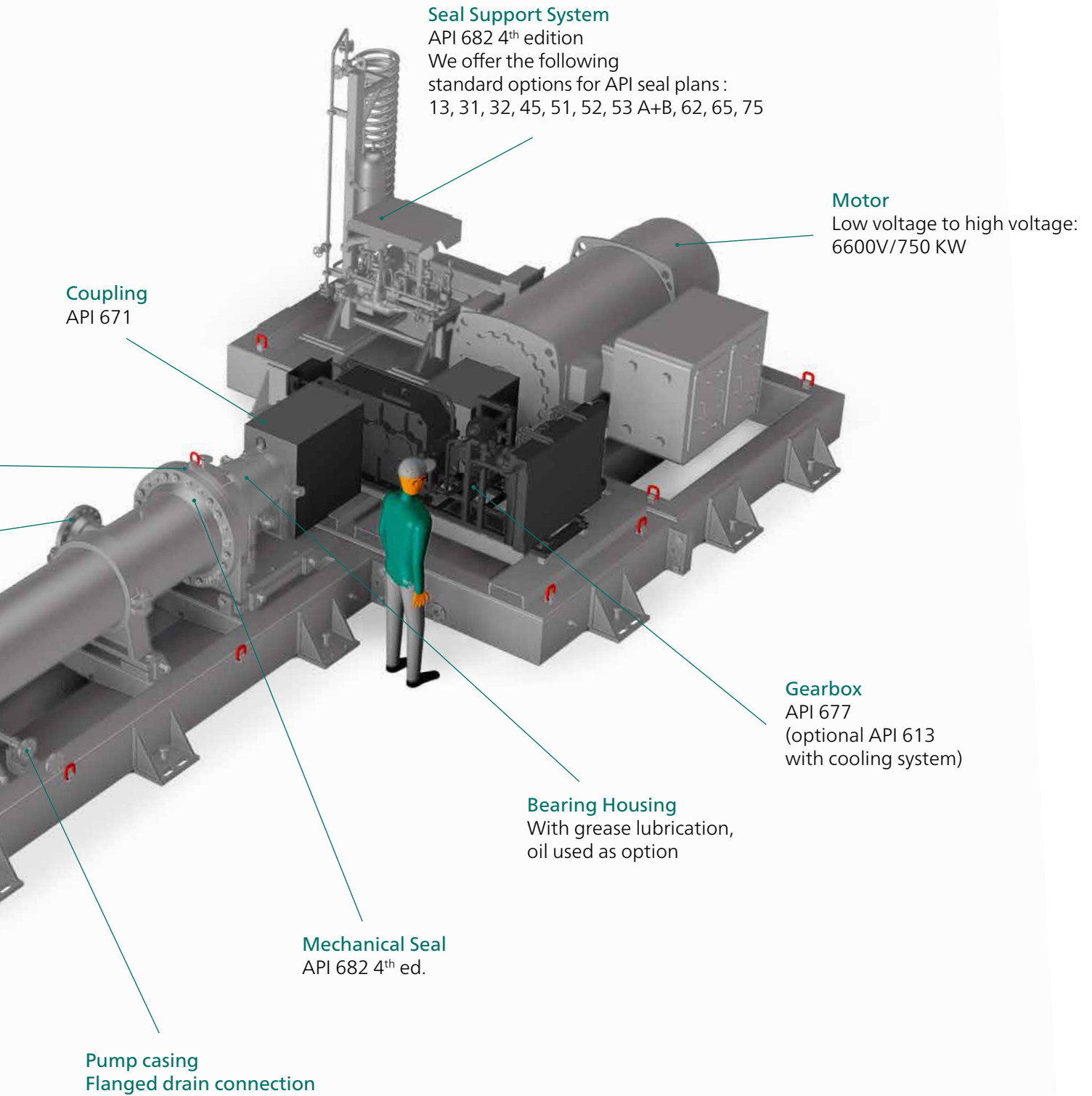

Seal Support System

API 682 4th edition

We offer the following standard options for API seal plans :
13, 31, 32, 45, 51, 52, 53 A+B, 62, 65, 75

Motor

Low voltage to high voltage:
6600V/750 KW

Coupling

API 671

Gearbox

API 677
(optional API 613 with cooling system)

Bearing Housing

With grease lubrication,
oil used as option

Mechanical Seal

API 682 4th ed.

Pump casing

Flanged drain connection

Pump Data

Pump type:	NEMO® L.Cap® Progressing Cavity Pump
Capacity:	up to 1000 m ³ /h
Pressure:	up to 72 bar
Medium:	oil, gas or water mixtures with solids
Medium temperature:	up to 150 °C
Ambient temperature:	- 45 °C to + 58 °C

Applications

NEMO® progressing cavity pump

- Application: Multiphase Transfer
- Pump: NM148
- Multiphase: Crude Oil with water, sand and gas
- Flow: 150 m³/h
- Pressure: 26 bar
- GVF: 70 %



TORNADO® T2 rotary lobe pump

- Application: Oily water with H₂S
- Pump: TORNADO® T2 rotary lobe pump
- Media: Oily water
- Flow: 35 m³/h
- Pressure: 4,8 bar
- Temperature: 20-40 °C
- Viscosity: 0,5-200 cSt



NOTOS® multi screw pump

- Application: Fuel Oil Transfer
- Pump: NOTOS® 4NS
- Geared twin screw pumps
- Media: Fuel oil 1A
- Flow: 130 m³/h
- Pressure: 15,1 bar
- Temperature: 60 °C
- Viscosity: 605 cSt



NETZSCH Seal Support Systems

According to API682 4th edition the pump supplier is responsible for the complete unit including the sealing system. With the design of the NETZSCH system we achieve the integration between seal and the respective support systems. As a result your process will become more reliable and efficient.





The NETZSCH Group is a mid-sized, family-owned German company engaging in the manufacture of machinery and instrumentation with worldwide production, sales, and service branches.

The three Business Units – Analyzing & Testing, Grinding & Dispersing and Pumps & Systems – provide tailored solutions for highest-level needs. Over 3,500 employees at 210 sales and production centers in 35 countries across the globe guarantee that expert service is never far from our customers.

The NETZSCH Business Unit Pumps & Systems offers with NEMO® progressing cavity pumps, TORNADO® rotary lobe pumps, NOTOS® multi screw pumps, macerators/grinders, dosing technology and equipment custom built and challenging solutions for different applications on a global basis.

Proven Excellence.■

NETZSCH Pumpen & Systeme GmbH
Geretsrieder Straße 1
84478 Waldkraiburg
Germany
Tel.: +49 8638 63-0
Fax: +49 8638 67981
info.nps@netzsch.com

NETZSCH®

www.netzsch.com